



Benjamin Kusserow

Troop 17

Eagle Scout Project

Ladder Golf Courts at Camp
Lutherlyn



EAGLE SCOUT RANK APPLICATION

TO THE EAGLE SCOUT RANK APPLICANT. This application is to be completed after you have completed all requirements for the Eagle Scout rank. **Print in ink or type all information. List the month, day, and year for all dates.** When using computer date blocks list the date: July 8, 1970, as 07 (for July) 08 (for day) 70 (for year). When you have completed this application, sign it and submit it to your unit leader.

FOR COUNCIL USE ONLY	
COUNCIL NO.	TYPE OF UNIT
REGION C, N, S, W	NATIONAL NO.
NAME ON OFFICIAL REGISTRATION	
PID NO. (REQUIRED)	

LIST YOUR FULL LEGAL NAME (UP TO 30 CHARACTERS ONLY).

B e n j a m i n F r e d e r i c k K u s s e r o w

2800 McCully Rd.

Street or R.F.D. Address

Allison Park, PA, 15101

City, state, zip

412-486-0267

Telephone (Including area code)

Troop 17

Troop, Team, Crew, or Ship Local No.

Allison Park, PA, 15101

City, state, zip

Date joined a Boy Scout troop

Date became a Varsity Scout

Date became a Venturer

Date of First Class Scout board of review

Date of Star Scout board of review

Were you a Cub Scout?

Were you a Webelos Scout?

Did you earn the Arrow of Light Award?

Had you completed fifth grade upon joining?

Month	Day	Year
0 2	2 6	0 3
- -	- -	- -
- -	- -	- -
0 9	2 8	0 4
0 2	0 1	0 5

Yes No
 Yes No
 Yes No
 Yes No

AGE REQUIREMENT ELIGIBILITY. Merit badges, badges of rank, and Eagle Palms may be earned by a registered Boy Scout, Varsity Scout, or Venturer. He may earn these awards until his 18th birthday. Any Venturer who achieved the First Class rank as a Boy Scout in a troop or Varsity Scout in a team may continue working for the Star, Life, and Eagle Scout ranks and Eagle Palms while registered as a Venturer up to his 18th birthday. Scouts and Venturers who have completed all requirements prior to their 18th birthday may be reviewed within three months after that date with no explanation. Boards of review conducted between three and six months after the candidate's 18th birthday must be preapproved by the local council. A statement by an adult explaining the reason for the delay must be attached to the Eagle Scout Rank Application when it is submitted to the Eagle Scout Service. The Boy Scout Division at the national office must be contacted for procedures to follow if a board of review is to be conducted more than six months after a candidate's 18th birthday.

A Scout or Venturer with a disability may work toward rank advancement after he is 18 years of age. See *Advancement Committee Policies and Procedures* for details.

REQUIREMENT 1. Be active in your troop, team, crew, or ship for a period of at least six months after you have achieved the rank of Life Scout.

REQUIREMENT 2. Demonstrate that you live by the principles of the Scout Oath and Law in your daily life. List the names of individuals who know you personally and would be willing to provide a recommendation on your behalf.

Date of birth 1 2 2 9 9 1
 Month Day Year

Date of Life Scout board of review 0 9 0 6 0 5
 Month Day Year

	Name	Address	Telephone
Parents/guardians	Kurt and Pam Kusserow	2800 McCully Rd. Allison Park PA 15101	412-486-0267
Religious	Pastor Tony Schneck	714 Willruth Drive Allison Park PA 15101-4133	412-486-4203
Educational	Mr. Chad Himmler	2929 McCully Rd. Allison Park PA 15101	412-486-6000
Employer (if any)	Deb Roberts	PO Box 355 Prospect PA 16052	725-865-2999
Two other references	Greg Yothers	1943 Brinkerton Rd. Greensburgh PA 15601	724-423-4619
	Pastor Scott Bryte	517 Sangree Rd. Pittsburgh PA 15237-3949	412-837-2227

REQUIREMENT 3. Earn a total of 21 merit badges (required badges are listed). List the month, day, and year the merit badge was earned.

MERIT BADGE	DATE EARNED	UNIT NO.	MERIT BADGE	DATE EARNED	UNIT NO.	MERIT BADGE	DATE EARNED	UNIT NO.
1 CAMPING	0 7 0 9 0 4		8 FIRST AID	0 7 0 9 0 4		15 Geology	0 7 0 7 0 6	
2 CITIZENSHIP IN THE COMMUNITY	0 3 2 0 0 4		9 BICYCLING OR CANOEING OR SWIMMING	0 7 0 8 0 5		16 Weather	0 7 0 7 0 6	
3 CITIZENSHIP IN THE NATION	0 6 1 5 0 4		10 PERSONAL MANAGEMENT	0 4 1 9 0 5		17 Salesmanship	0 1 1 8 0 5	
4 CITIZENSHIP IN THE WORLD	0 3 2 9 0 8		11 PERSONAL FITNESS	1 0 2 4 0 6		18 Mammal Study	0 7 0 9 0 4	
5 COMMUNICATIONS	1 1 1 0 0 9		12 FAMILY LIFE	0 9 2 3 0 8		19 Wood Carving	0 7 0 9 0 4	
6 EMERGENCY PREPAREDNESS OR FIRE FIGHTING	0 3 2 1 0 9		13 Space Exploration	0 7 0 8 0 5		20 Leatherwork	0 7 0 8 0 5	
7 ENVIRONMENTAL SCIENCE	0 7 0 8 0 5		14 Music	0 1 1 0 0 6		21 Radio	1 2 0 1 0 8	

*Cross out badges not earned. If a crossed-out badge was earned, it may be reentered in 13 through 21. Four of these required merit badges were earned for the Star Scout rank and three more were earned for the Life Scout rank.

REQUIREMENT 4. While a Life Scout, serve actively for a period of six months in one or more of the following positions of responsibility. List only those positions served after Life board of review date.

Boy Scout troop. Patrol leader, Venture patrol leader, assistant senior patrol leader, senior patrol leader, troop guide, Order of the Arrow troop representative, den chief, scribe, librarian, historian, quartermaster, bugler, junior assistant Scoutmaster, chaplain aide, instructor

Varsity Scout team. Captain, cocaptain, program manager, squad leader, team secretary, Order of the Arrow team representative, librarian, historian, quartermaster, chaplain aide, instructor, den chief

Venturing crew/ship. President, vice president, secretary, treasurer, den chief, quartermaster, historian, guide, boatswain, boatswain's mate, yeoman, purser, storekeeper

Date of Life Scout board of review

0	9	0	6	0	5
Month		Day		Year	

Position Bugler

FROM

0	9	1	6	0	8
Month		Day		Year	

 TO

1	0	0	6	0	9
Month		Day		Year	

Position Patrol Leader

FROM

0	3	1	8	0	8
Month		Day		Year	

 TO

0	9	1	8	0	8
Month		Day		Year	

REQUIREMENT 5. While a Life Scout, plan, develop, and give leadership to others in a service project helpful to any religious institution, any school, or your community. The project plan must be approved by your Scoutmaster and troop committee, by the council or district, and by the organization benefiting from the effort before you start. You must use the *Eagle Scout Leadership Service Project Workbook, No. 18-927, in meeting this requirement.*

Project name: Ladder Golf Courts at Camp Lutherlyn

Date of final signature

1	1	2	2	0	9
Month		Day		Year	

Grand total of hours: 153 (from page 10 of *Eagle Scout Leadership Project Workbook*—for statistical purposes only)

REQUIREMENT 6. Take part in a Scoutmaster conference (with Scoutmaster, Coach, or Advisor). Attach to this application a statement of your ambitions and life purpose and a listing of positions held in your religious institution, school, camp, community, or other organizations during which you demonstrated leadership skills. Include honors and awards received during this service.

Date conference was held

1	1	2	3	0	9
Month		Day		Year	

CERTIFICATION BY APPLICANT. On my honor as a Scout/Venturer, all statements on this application are true and correct. All requirements were completed prior to my 18th birthday.

Signature of applicant Ben Nasson

Telephone 412-486-0267

Date

1	1	2	3	0	9
Month		Day		Year	

UNIT APPROVAL (personal signatures required)

Signature of unit leader Walt Smith
Scoutmaster, Coach, or Advisor

Telephone 724-449-2266

Date

1	1	2	3	0	9
Month		Day		Year	

Signature of unit committee chair M. Williams

Telephone 412-973-7699

Date

1	1	2	4	0	9
Month		Day		Year	

BSA LOCAL COUNCIL CERTIFICATION. According to the records of this council, the applicant is a registered member of this unit and this application is approved as accurate.

Signed Carol King Position CSR

Date

1	1	2	5	0	9
Month		Day		Year	

REQUIREMENT 7. Successfully complete an Eagle Scout Board of Review. The applicant appeared before the Eagle Scout board of review on this date, and this application was approved.

Review date

Month		Day		Year	

This date will be used on the Eagle Scout credentials.

Signature of Eagle Scout board of review chairman

Signature of council/district board representative (if applicable)

I certify that all procedures, as outlined in *Advancement Committee Policies and Procedures*, have been followed. I approve this application.

Scout Executive _____

Date

Month		Day		Year	

Presentation of the rank may not be made until the Eagle Scout credentials are received by the BSA local council.



NATIONAL EAGLE SCOUT ASSOCIATION. The National Eagle Scout Association is a fellowship of men who have achieved the Eagle Scout rank. Membership embraces the top achievers of the Boy Scouts of America. Benefits include a subscription to *Eagleletter*. The journal keeps NESA members informed on Scouting in general and Eagle Scouting in particular.

Applications are available at your local council service center.

Regular five-year memberships are \$25. Life memberships are \$180.

EDITIONS OF THIS APPLICATION PREVIOUS TO THE 2008 REVISION SHOULD NOT BE USED.

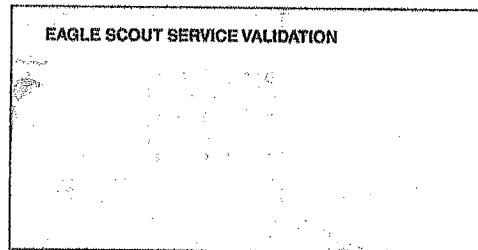

58-728



7 30176 30600 1

My Life: Past, Present, and Future

My first goal that I want to reach is graduating Hampton High School with a 4.0 GPA or above. After that, I plan on attending Allegheny College for four years. I am thinking of majoring in Chemistry or Chemical Engineering, but this may change over my four years at Allegheny. I then am planning on going for my masters at Penn State University Main Campus in their Materials Engineering field.

My life purpose in a nutshell is to be successful in life. This has a variety of meanings. I want to become a successful Lutheran. This means following God wherever he calls me to go. Also becoming an active church member in a congregation is important to me. I want to become a successful father. I plan, many years down the line, to have a family of my own. With that family, I want to be the best father that I can be and educate my children so they can live in the real world. I want to become a successful employee. Whatever job I end up working at, I want to do well at my job. Not just for the money, but for getting the job done. I want to become a successful citizen. I do not plan on running for any public office but I do plan on doing my part and voting for the issues I believe in when I am old enough.

Over the years I have helped out with many organizations. I have been in Latin club, Hampton High School marching band, church activities like flea markets and bake sales, working at a camp Lutherlyn, and of course Boy Scouts. I have won Magnum Cum Laude and two silver medals in Latin. In marching band, I have been a section leader of the trumpet section for two years in a row. My section and others in the band have said that I have been a successful section leader not because of my playing abilities

(since I do not play first trumpet) but in being a good example for others and informing my section what they need to do very clearly. Both Hampton High School and Mt. Pleasant High School, the school I attended until my freshmen year, have put me on their Honor Roll for all the years that I have been in school. In scouts I have been everything from Assistant Senior Patrol Leader, to Chaplin, to Bugler.

Table of Contents

Tab

Approved

Project Description and Benefits to Lutherlyn camp.....	A
Fundraising.....	B
Preparation Work.....	C
Camp Work Day.....	D
Safety.....	E
Materials Needed.....	F
Bolas.....	G
Ladders.....	H
Equipment Box.....	I
Bench.....	J
Pictures (Before and imposed), Layout of Courts.....	K

Completion

Materials List and Receipts.....	L
Completion Write Up and Changes.....	M
Project Pictures (Fundraising, building, work days, etc.).....	N
Miscellaneous.....	O

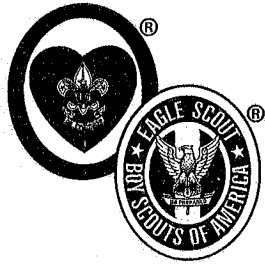

Eagle Scout

Leadership Service

Project Workbook

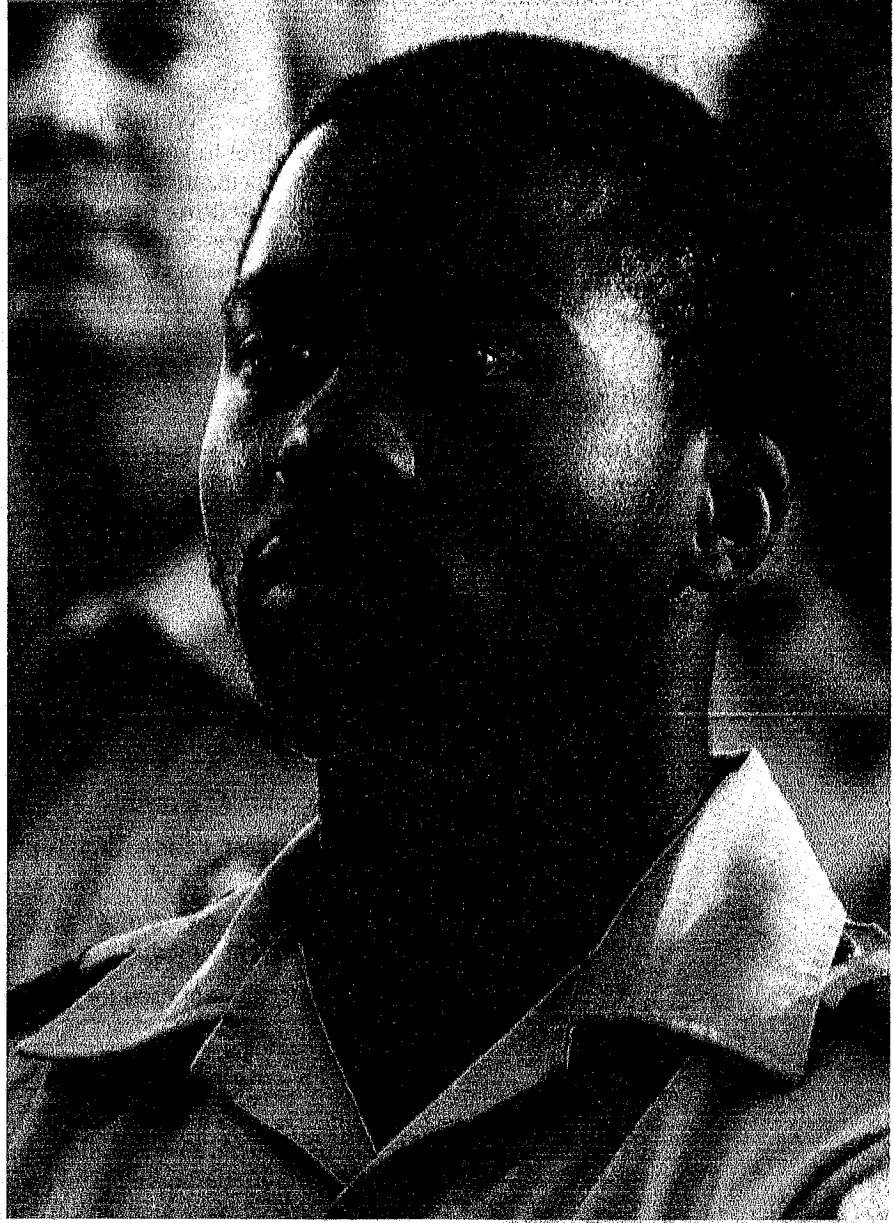

BOY SCOUTS  OF AMERICA®

Your Eagle Scout Leadership Service Project



How to Start

You have earned the Life Scout rank and are ready to begin your Eagle Scout leadership service project. This workbook will help you plan and record your progress and complete and submit a final report.

The Requirement

As stated in *The Boy Scout Handbook*: While a Life Scout, plan, develop, and give leadership to others in a service project helpful to your religious institution, school, or your community. (The project should benefit an organization other than the BSA.) **The project plan must be approved by the organization benefiting from the effort, your unit leader (Scoutmaster, Varsity Scout Coach, Venturing crew Advisor), unit committee, and by the council or district advancement committee before you start. You must use this Eagle Scout Leadership Service Project Workbook (No. 18-927E or its online equivalent on the National Eagle Scout Association's Web site, <http://www.NESA.org>) in meeting this requirement.**

Originality

Does the leadership service project for Eagle have to be original, perhaps something you dream up that has never been done before? The answer: No, but it certainly could be. You may pick a project that has been done before, but you must accept responsibility for planning, directing, and following through to its successful completion.

Limitations

- Routine labor (a job or service normally rendered) should not be considered.
- Projects involving council property or other BSA activities are not acceptable.
- Projects may not be performed for businesses.
- Projects may not be of a commercial nature.
- Projects may not be a fund-raiser. Fund-raising is permitted only for securing materials needed to carry out the project.
- Donors to projects must be made aware of what entity is benefiting from the project, and that it clearly is not the Boy Scouts of America.
- Any funds raised for a project and not used for the purchase of project materials must be returned to the donors.

Size

How big a project is required? There are no specific requirements, as long as the project is helpful to a religious institution, school, or community. The amount of time spent by you in planning your project and the actual working time spent in carrying out the project should be as much as is necessary for you to demonstrate your leadership of others.

Eagle Scout
Leadership Service
Project Workbook

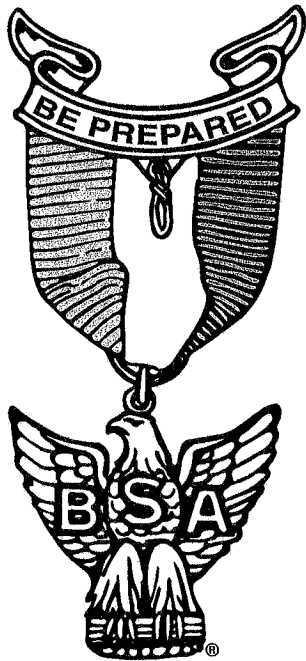

Benjamin Kusserow
Scout's name
2800 Melody Rd. Allison Park PA 15101
Address
412-486-0267
Telephone No. 12/29/1991
Date of birth
bfk410@yahoo.com
E-mail (optional)

17
Unit No.
Sapeechen
District
Greater Pittsburgh
Local council

Walt Garida
Unit leader's name
3349 East Hardies Rd. Gibsonia PA 15044
Address
724-449-2266
Telephone No.

Mark Riethmuller
Unit advancement committee person's name
4721 Hidden Pond Dr. Allison Park PA 15101
Address
412-487-3421
Telephone No.

Examples

A look at some projects other Scouts have done for their Eagle Scout Award illustrates that your project can be to construct something or can be to render a service. Scouts have

- Made trays to fasten to wheelchairs for veterans with disabilities at a Veterans Administration hospital.
- Collected used books and distributed them to people in the community who wanted and needed, but could not afford, books.
- Built a sturdy footbridge across a brook to make a safe shortcut for children between their homes and school.
- Collected and repaired used toys and gave them to a home for children with disabilities.
- Organized and operated a bicycle safety campaign. This involved a written safety test, equipment safety check, and a skills contest in a bike rodeo.
- Surveyed the remains of an old Spanish mission and prepared an accurate map relating it to the present church.
- Built a "tot lot" in a big city neighborhood and set up a schedule for Boy Scouts to help run it.
- Set up a community study center for children who needed a place to do schoolwork.
- Trained fellow students as audiovisual aides for their school. Arranged for more than 200 hours of audiovisual work.
- Prepared plans for a footbridge on a trail in a national forest. Worked with rangers to learn the skills necessary to build the structure, gathered materials and tools, and then directed a Scout work group to do the construction.

Approvals

Before You Start

The project plan must be reviewed and approved by the beneficiary of the project, your unit leader, the unit committee, and the council or district advancement committee before the project is started. The following questions must be answered before giving this approval:

- What is the project you are planning?
- Who will benefit from the project?
- How will they benefit?
- What representative of the project's beneficiary will be contacted for guidance in planning the project?
- What are the project planning details?

Remember, the project must be approved before you begin, so make sure all signatures have been secured before you start the project. You must be a Life Scout before you begin an Eagle Scout leadership service project.

After Completion

Although your project was preapproved by the project's beneficiary, your unit leader, the unit committee, and the council or district advancement committee before it was begun, the Eagle Scout board of review must approve the manner in which it was carried out. The following must be answered:

- In what ways did you demonstrate leadership of others?
- Give examples of how you directed the project rather than doing the work yourself.
- In what way did the religious institution, school, or community group benefit from the project?
- Did the project follow the plan?
- If changes to the plan were made, explain why the changes were necessary.

Filling Out the Form

As you plan and carry out your leadership service project, use this workbook to record your plans and progress. Remember that others will be reading these pages. You should print, type, or write legibly using black or blue ink. Complete the form on a computer if you have access to an electronic version. You may add as many pages as needed to thoroughly complete the workbook.

National Eagle Scout Association

The National Eagle Scout Association was created in 1972 with the express purpose of bringing together Eagle Scouts of all ages so that they may be of greater service to themselves, their local councils, and their communities, thereby conserving and developing the human resources potential represented by those who hold Scouting's highest rank.

When you receive your Eagle badge, you will be eligible for membership in this elite association. You should give it serious consideration. Applications are available from your local council service center.

PROJECT DESCRIPTION

Project name Ladder Golf Courts at Camp Lutherlyn

Describe the project you plan to do.

See Tab A

What group will benefit from the project?

Camp Lutherlyn
Name of religious institution, school, or community

724-865-2161
Telephone No.

P. O. Box 355
Street address

Prospect
City

PA
State

16052
Zip code

My project will be of benefit to the group because:

See Tab A

This concept was discussed with my unit leader on

3/10/09
Date

The project concept was discussed with the following representative of the group that will benefit from the project.

Randall K. Sullickson
Representative's name

3/11/09
Date of meeting

EXECUTIVE DIRECTOR
Representative's title

(724)865-2161
Phone No.

PROJECT DETAILS

Plan your work by describing the present condition, the method, materials to be used, project helpers, a time schedule for carrying out the project, the estimated cost of the project, and how the needed funds will be obtained. Describe any safety hazards you might face, and explain how you will ensure the safety of those carrying out the project.

If appropriate, include photographs of the area before you begin your project. Providing before-and-after photographs of your project area can give a clear example of your effort.

See Tabs B-J

"BEFORE" PHOTOGRAPHS

See Tab K

Approval Signatures for Project Plan

Project plans were reviewed and approved by

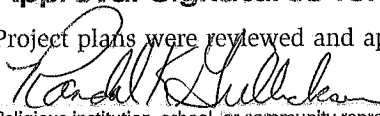
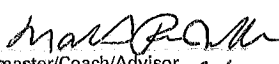
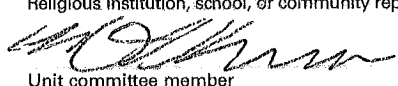
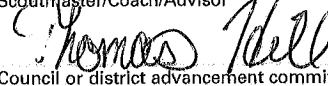
	3/11/09		3/11/09
Religious institution, school, or community representative	Date	Scoutmaster/Coach/Advisor	Date
	3/11/09		3/11/09
Unit committee member	Date	Council or district advancement committee member	Date

IMPORTANT NOTE: You may proceed with your leadership service project only when you have

- Completed all the above mentioned planning details
- Shared the project plans with the appropriate persons
- Obtained approval from the appropriate persons

CARRYING OUT THE PROJECT

Record the progress of your project. Keep a record of how much time you spend planning and carrying out the project. List who besides yourself worked on the project, the days they worked, the number of hours they worked each day, and the total length of time others assisted on the project.

If appropriate, list the type and cost of any materials required to complete the project. If your original project plan changes at any time, be sure to document what the change was and the reason for the change.

Hours I Spent Working on the Project

The length of time spent should be as adequate as is necessary for you to demonstrate your leadership of two or more individuals in planning and carrying out your project.

Hours I spent: Planning the project 20 Carrying out the project 49

Total hours I spent working on the project: 69

Hours Spent by Scouts, Venturers, or Other Individuals Working on the Project

Name	Date	No. of Hours
------	------	--------------

See Timeline and Completion of Eagle scout project at TAB M		
---	--	--

Total number of hours others worked on the project: 84

For a grand total, add the total number of hours you spent on the project to the total number of hours others worked on the project: 153

Materials Required to Complete the Project

Type of Material

Cost of Material

See Tab L

Changes

List any changes made to the original project plan and explain why those changes were made.

See Tab M

"AFTER" PHOTOGRAPHS

See Tab N

Including photographs of your completed project (along with the "before" photographs on page 9) helps present a clearer overall understanding of your effort.

Approvals for Completed Project

Start date of project 4/9 Completion date of project 6/07

The project was started and has been completed since I received the Life Scout rank, and is respectfully submitted for consideration.

B. Kussner 11/22/09
Applicant's signature Date

This project was planned, developed, and carried out by the candidate.

Walt Smith 11/22/09
Signature of Scoutmaster/Coach/Advisor Date
Randal K. Shullhoke 11/22/09
Signature of the representative of religious institution, school, or community Date

The 12 Steps from Life to Eagle

The following 12 steps have been outlined to ensure a smooth procedure for the Scout, the unit leadership, the local council, and the volunteers who are to conduct the board of review. Eagle candidates should share these steps with their unit leader so that they can fully understand the procedures that must be followed.

1. In order to advance to the rank of Eagle, while a Life Scout, a candidate must complete all the requirements of active tenure; Scout spirit; any remaining merit badges; positions of responsibility; planning, developing, and providing leadership to others in a service project; and the Scoutmaster conference.
2. Using the Eagle Scout Leadership Service Project Workbook, the candidate must select his Eagle service project and have the project concept approved by his unit leader, his unit committee, and the benefactor of the project, and reviewed and approved by the council or district advancement committee. This workbook must be used in meeting this requirement.
3. It is imperative that all requirements for the Eagle Scout rank except the board of review be completed prior to the candidate's 18th birthday. When all requirements except the board of review for the rank of Eagle, including the leadership service project and Scoutmaster conference, have been completed, the enclosed Eagle Scout Rank Application must be completed and sent to the council service center promptly. (Youth members with disabilities should meet with their unit leader regarding time extensions.)
4. The application should be signed by the unit leader at the proper place. The unit committee reviews and approves the record of the Eagle candidate before the application is submitted to the local council. If a unit leader or unit committee fails to sign or otherwise approve an application, the Eagle candidate may still be granted a board of review. The failure of a unit leader or unit committee to sign an application may be considered by the board of review in determining the qualification of the Eagle candidate.
5. The Eagle Scout Leadership Service Project Workbook, properly filled out, must be submitted with the application.
6. When the completed application is received at the council service center, its contents will be verified and the references contacted. The Scout shall have listed six references (five if no employer, and parent if no organized religious association). The council advancement committee or its designee contacts the references on the Eagle Scout Rank Application by letter, form, or telephone checklist. (The council determines the method or methods to be used.) The candidate should have contacted those individuals listed as references before including their names on the application. If desired by the council, the candidate may be asked to deliver a blank reference form and envelopes to the listed references. The candidates should not be involved personally in transmitting any correspondence between persons listed as references and the council service center or advancement committee. If the initial reference letter or form is not returned to the council in a timely manner, the council advancement committee must make direct contact with the reference(s) listed on the Eagle Scout Rank Application on its own, by follow-up letter, phone contact, or other methods as it chooses. The candidate shall not be required to make a follow-up contact with the reference or submit other reference names. A Scout cannot have a board of review denied or postponed because the council office or council advancement committee does not receive the reference letter forms he delivered.
7. After the contents of an application have been verified and appropriately signed, the application, Eagle Scout Leadership Service Project Workbook, and references will be returned from the council service center to the chairman of the Eagle board of review so that a board of review may be scheduled. Under no circumstances should a board of review be scheduled until the application is returned to the chairman of the Eagle board of review. Reference checks that are forwarded with the application are confidential, and their contents are not to be disclosed to any person who is not a member of the board of review.
8. The board of review for an Eagle candidate is composed of at least three but not more than six members. One member serves as chairman. Unit leaders, assistant unit leaders, relatives, or guardians may not serve as members of a Scout's board of review. The board of review members should convene at least 30 minutes before the candidate appears in order to review the application, reference checks, and leadership service project report. At least one district or council advancement representative must be a member of the Eagle board of review if the board of review is conducted on a unit level. A council or district may designate more than one person to serve as a member of Eagle boards of review when requested to do so by the unit. It is not required that these persons be members of the advancement committee; however, they must have an understanding of the importance of the Eagle board of review.
9. The candidate's unit leader introduces him to the members of the board of review. The unit leader may remain in the room, but does not participate in the board of review. The unit leader may be called on to clarify a point in question. In no case should a relative or guardian of the candidate attend the review, even as a unit leader. There is no set of questions that an Eagle candidate should be asked. However, the board should be assured of the candidate's participation in the program. This is the highest award that a Scout may achieve and, consequently, a thorough discussion of his successes and experiences in Scouting should be considered. After the review, the candidate and his unit leader leave the room while the board members discuss the acceptability of the candidate as an Eagle Scout. **The decision must be unanimous.** If the candidate meets the requirements, he is asked to return and is informed that he will receive the board's recommendation for the Eagle Scout rank. If the candidate does not meet the requirements, he is asked to return and told the reasons for his failure to qualify. A discussion should be held with him as to how he may meet the requirements within a given period. Should the applicant disagree with the decision, the appeal procedures should be explained to him. A follow-up letter must be sent to the Scout confirming the agreements reached on the action(s) necessary for the advancement. If the Scout chooses to appeal, the board should provide the name and address of the person he is to contact. (See "Appealing a Decision" in *Advancement Committee Policies and Procedures*, No. 33088.)
10. Immediately after the board of review and after the application has been appropriately signed, the application, the service project report, references, and a properly completed Advancement Report are returned to the council service center.
11. When the application arrives at the council service center, the Scout executive signs it to certify that the proper procedure has been followed and that the board of review has recommended the candidate for the Eagle Scout rank. This workbook and references are retained by the council. The workbook may be returned to the Scout after council approval.
Only the Eagle Scout Rank Application is forwarded to the national Eagle Scout Service.
12. The Eagle Scout Service screens the application to ascertain information such as proper signature, positions of responsibility, tenure between ranks, and age of the candidate. Any item not meeting national standards will cause the application to be returned for more information. If the application is in order, the Scout is then certified as an Eagle Scout by the Eagle Scout Service on behalf of the National Council. Notice of approval is given by sending the Eagle Scout certificate to the local council. The date used on the certificate will be the date of the board of review. The Eagle Award must not be sold or given to any unit until after the certificate is received by the council service center. The Eagle Scout court of honor should not be scheduled until the local council receives the Eagle Scout rank credentials. After earning the Eagle Scout Award, a Scout may work to earn Eagle Palms. An Eagle Palm or Palms must be earned before the Scout's 18th birthday. Palms must be earned one at a time, in the order of Bronze, Gold, and then Silver. Each Palm level can only be earned after a three-month tenure since earning the last Palm and by satisfactory completion of all of the other requirements for the next Palm.



BOY SCOUTS OF AMERICA
1325 West Walnut Hill Lane
P.O. Box 152079
Irving, TX 75015-2079
<http://www.scouting.org>

18-927E



7 30176 30287 4

2008 Printing

Project Description

The project that I plan to do is building two Ladder Golf courts for Lutherlyn camp in Prospect PA. Ladder Golf is a game like horse shoes, in that two teams are facing each other throwing bolas, or two golf balls attached to a rope, at a ladder approximately 20 feet away. There will also be a bench and an equipment box to hold the rules and bolas.

Benefits to Lutherlyn camp

This is a game that I know through personal experience the campers enjoy playing and also is a nice, permanent, easy to care for addition to the camp. The camp director also has expressed a need for a permanent Ladder Golf court to add to the recreation part of the summer program. This is not the first Ladder Golf court the camp has owned. The ones that they had before were not permanent and were very weak being that they were made out of PVC pipe. The two courts which will be part of my project will be made of weather-proof steel piping and treated wood so that they can stand the elements.

Fundraising

To raise the amount of funds that I have estimated, two fundraisers will be used. First, I will sell hoagies from Mineo's Pizza as soon as possible (end of March). Mineo's will get some of the funds, but a significant portion of the proceeds will be acquired from the sales. I expect this to meet most of my budget. Also, Max & Erma's restaurant does a fundraiser in which they will give a portion of their proceeds from one night to a certain group, in this case to this eagle project. I will only use this fund raiser if I need to.

Advance Preparation work (see tab F for materials and tabs G-J for illustrations)

Before any preparation work, all the materials will need to be purchased (see tab F). I will do this after I meet my budget from the fundraising. Some of the pieces will need to be prepared in advance.

First, eight of the posts will need to have two feet cut off of the end, since only six feet of these posts is needed. Each post will also have three $\frac{3}{4}$ inch holes pre-drilled. The centers of those holes will be 3 inches from the end, 21 inches, and 39 inches all measured from the same end. The ninth post will only need 18 inches cut off. Also, each golf ball will have a $\frac{3}{4}$ inch hole drilled through it so that the rope can go through.

The pieces for the equipment box will also be cut to length. The pieces needed and how to cut them (only an adult will cut these pieces because power tools are needed) are:

Two pieces that are 20 inches long and 12 inches wide:

From the mid point of the short side, cut a 60 degree angle (in respect to the side) making a 10 inch long cut. Make another 60 degree angle from the same point so that the top of the piece is pointed (see tab I). Repeat this on the second piece.

One piece will be the back, and the other the front.

One piece that is 11 inches by 12 inches:

Cut a 4 inch by 4 inch hole in the center of one of the 11 inch sides, to accommodate the 4 inch post (see tab I). This will be the floor.

Two 11 inch by 13 inch pieces:

These will be roof pieces.

Two 12 inch by 12 inch pieces:

These will be the sides of the box.

Two triangular pieces with a height of six inches and a width of one inch:

Note; it is important that these are not equilateral triangles but right triangles because they will serve as braces for the rules pocket on the inside of the door.

One rectangular piece that is 6 inches by 9 inches:

This will be attached to the two triangular pieces mentioned above to hold the laminated rules pages.

Cutting door out of front piece:

Using a scroll saw, the front door will be cut out of the front piece. Its sides will be parallel to the sides of the front piece, its width ten inches, its top a curve yielding a maximum height of 14 inches (see tab I)

The above preparation work will be done by adults since power tools are involved.

Scout Preparation Day

When the above preparation work is finished, I will invite three to four scouts to help with the following preparation work at my house. We will start by tying all of the golf balls with rope. Each helper will put 1.5' of rope through two golf balls. They will then tie off each end tightly, but making sure that there is a foot of rope in-between each ball.

Using a brush, the scouts will apply wood finish to all the pieces of wood.

Protective eyewear will be mandatory for everyone working with the finish.

The construction of the box will be done next. We will nail together the floor piece, the two side wall pieces, and the back wall piece. The 4 inch by 4 inch hole should be right up against the back wall. Now insert the 4 inch by 4 inch post, (the one 78"

long) six inches up into the box. Holes will be drilled from the back wall to the post so that it can be attached with exterior wood screws. The roof will be nailed on, as well as the front piece after the post is secured. The felt paper will then be attached to the roof, along with the shingles. Next attach the slot unit and the handle to the front door (The slot unit will be attached to the inside of the door by taking the two triangles and nailing them to the inside of the door, parallel to each other and 9 inches apart [see tab I]. Then nail the 6 inch by 9 inch piece to the triangles.), and then the door will be attached to the box with steel hinges.

With three to four helpers, I predict the preparation work to take two hours. Food and drink will be provided by me.

Work Day on Site

Around eight or nine in the morning, I will take five to six scouts up to Lutherlyn camp which is near Prospect, PA. I will not be driving, but an adult will be. All the materials will also be taken up in the same vehicle. The project will start by plotting out the holes for the ladders and box. From one hole that will be the lower left part of the court, two feet to the right will be measured and a marker will be placed. From that hole, ten feet to the right will be measured and another marker will be placed. Another two feet from that, the fourth marker will be placed. From each marker, 20 feet will be measured perpendicularly from the markers and all measurements will be parallel. At each end of the 20 feet measured a marker will be placed. The last hole will be measured four feet to the right and four feet up from the lower left corner ladder. A final marker will be placed here. While the markers are being placed, other scouts will put together the ladders by putting the steel pipes through the holes in the posts, and fastening the caps onto them.

At each marker, a hole six inches in diameter and two feet deep will be dug. Once that is complete, the ladders and box posts will be put into their respective holes. To make sure they are level, a five foot board will be nailed to each post three feet up. The bottom of the board should be four feet away, therefore making a 3/4/5 triangle. The same process will be done to the perpendicular side of the post, so the post is level in all directions. The part of the board will be attached to the ground to make sure the post does not move. A post level will be used to make sure it is level.

The cement powder will then be poured in until it reaches four inches from the top of the hole. Water will be added until the powder is thoroughly dampened. A scout

will stir the mixture if needed with a stick to make sure the water is distributed evenly. A ten to twelve minute interval is needed to let the cement dry, but more time will be needed if the cement is not dry. While it is drying, the bench will be made.

Cement legs with bolts cast into them are available at camp. This style of bench is used in other places around the camp, so it will not be out of place. It also is very hard to lift, so the chance of it being moved is very low. The bench will be provided by the camp. (The stumps were made awhile ago by casting the bolts into the concrete while the mixture was drying). A board will be placed on top of the stumps where needed and a hammer will pound just enough to mark the places where the bolt holes will be drilled. At these locations, a large hole (1") will be drilled down from the top and within it a smaller hole (3/8") will be drilled. The bolts will come through the smaller holes and the washer and nut will then be placed on top (see counter sinking illustration, tab J).

The work should take two to three hours to complete. Food and water will be provided by me.

Safety

The scouts' safety and also the safety of other workers that help me are a huge priority. I understand that their safety is in my hands. Scouts, and all other workers under the age of 21, will not be using *any* power tools. I will plan my project so that those types of tools will not be needed heavily, but when they are, an adult will handle it. Everyone will keep a safe distance while the power tools are on. Also, the cement and wood finish are dangerous if they got in the eye, so safety eyewear like goggles and gloves will be worn when working with these materials. When taking scouts to and from Lutherlyn camp, only an adult will be driving the vehicle, to make sure the scouts are safe. All scouts and helpers will also need to keep hydrated and fed so they do not faint from dehydration.

Materials Needed

Item	Parts	Cost per part	Quantity	Total Cost
Ladders	4"X4"X8' pressure treated wooden post	\$ 8.00	9	\$ 72.00
	3/4" galvanized steel piping	\$ 10.70	12	\$ 128.40
	Nipple ends, 36" pipes			
	50 lb fast setting concrete mix, (Quikrete)	\$ 6.00	9	\$ 54.00
Equipment Box	3/4" galvanized steel caps	\$ 1.57	24	\$ 37.68
	1/2"X4'X8' pressure treated plywood	\$ 25.00	1	\$ 25.00
	Box of exterior galvanized nails 2 1/2 "	\$ 4.50	1	\$ 4.50
	Box of construction screws 2"	\$ 2.19	1	\$ 2.19
	Hinges, galvanized steel	\$ 3.00	2	\$ 6.00
	Handle, galvanized steel	\$ 2.00	1	\$ 2.00
	Felt paper, three square feet	\$ 5.00	1	\$ 5.00
	Shingles, 2-3	\$ -	2 or 3	\$ -
Bolas	Golf balls (comes in pack of twelve)	\$ 6.30	4	\$ 25.20
	Twisted nylon and Polyester Rope 3/8" 50'	\$ 16.00	1	\$ 16.00
Bench	Pressure treated wood board	\$ -	1	\$ -
	Concrete legs	\$ -	2	\$ -
Tools needed	Hammer	\$ -	2	\$ -
	Power drill	\$ -	1	\$ -
	Post hole digger	\$ -	1	\$ -
	2" Chip brush	\$ 1.15	6	\$ 6.90
	Post level	\$ -	1	\$ -
	Table saw	\$ -	1	\$ -
	Scroll saw	\$ -	1	\$ -
Misc.	Wood toned wood finish, one gallon	\$ 25.00	1	\$ 25.00
	Lamination of rule sheet	\$ 0.50	20	\$ 10.00
	Food and Drink for helpers	\$ 50.00	1	\$ 50.00
Estimated Total Cost of Project		\$ 469.87		

BOLOS

(One of 20)

■ Twisted nylon and polyester rope

■ Golf ball

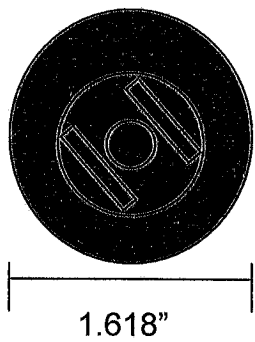
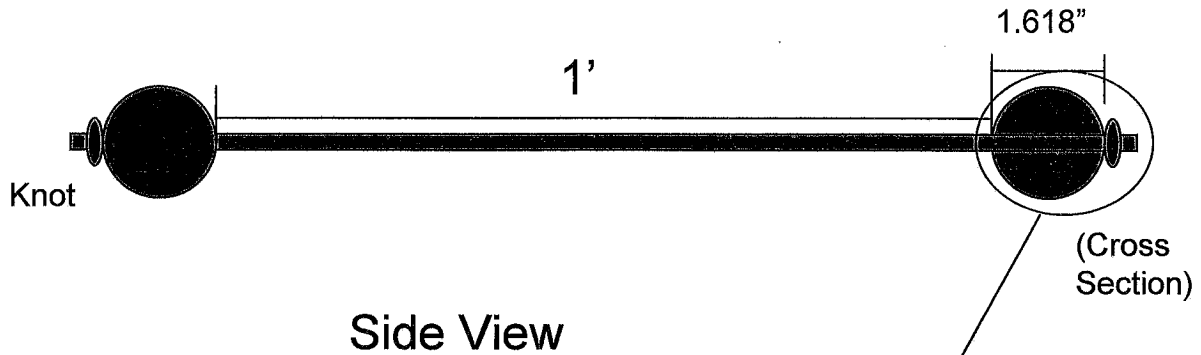

Front View

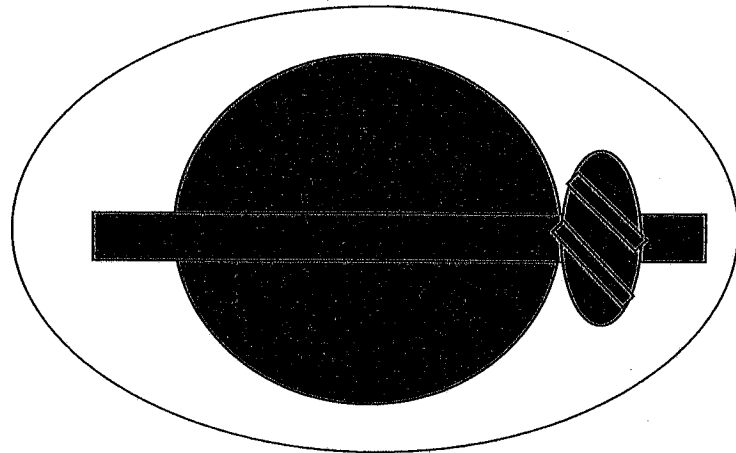

Ladders (One of Four)

- 4"X4"X8' Pressure treated wooden posts
- Galvanized steel pipe
- Galvanized steel caps
- Fast setting concrete

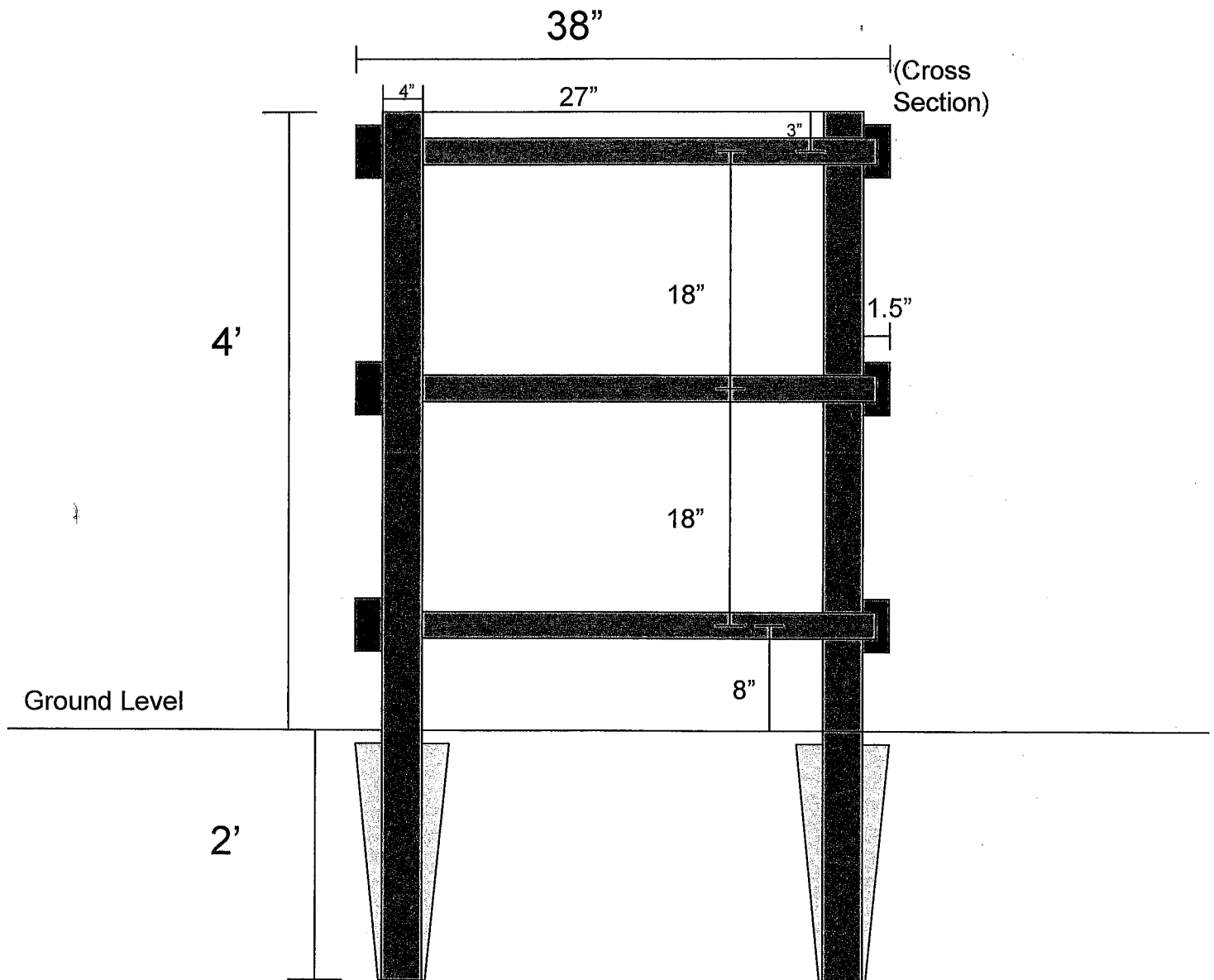

Equipment Box

- 4"x4"X8' Pressure treated wooden post
- Pressure treated plywood
- Felt Paper
- Cement
- Construction screws

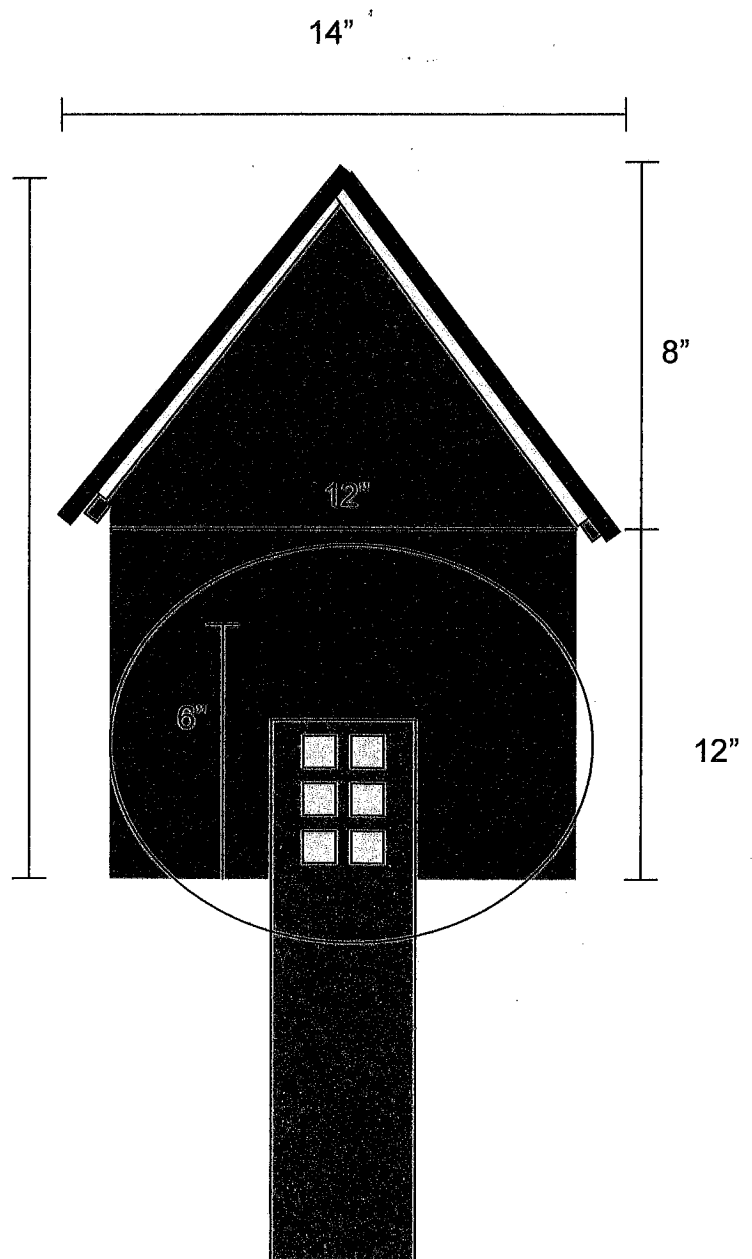
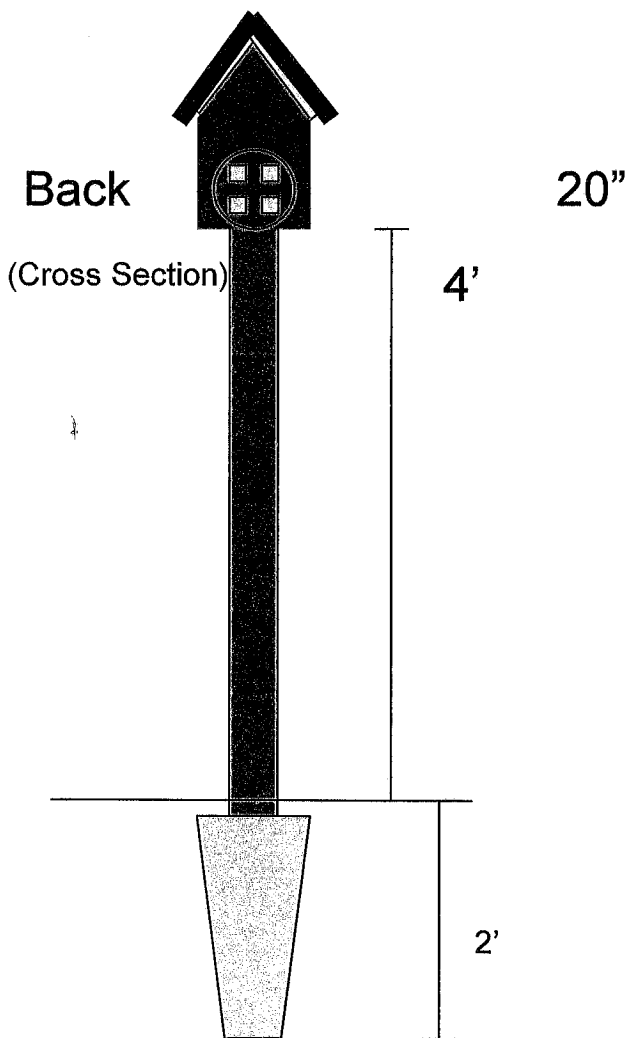

Equipment Box cont.

- Pressure treated plywood
- 4"X4"X8' pressure treated wooden post
- Galvanized steel (hinges, handle)
- Asphalt shingles
- Roofing felt paper

Front

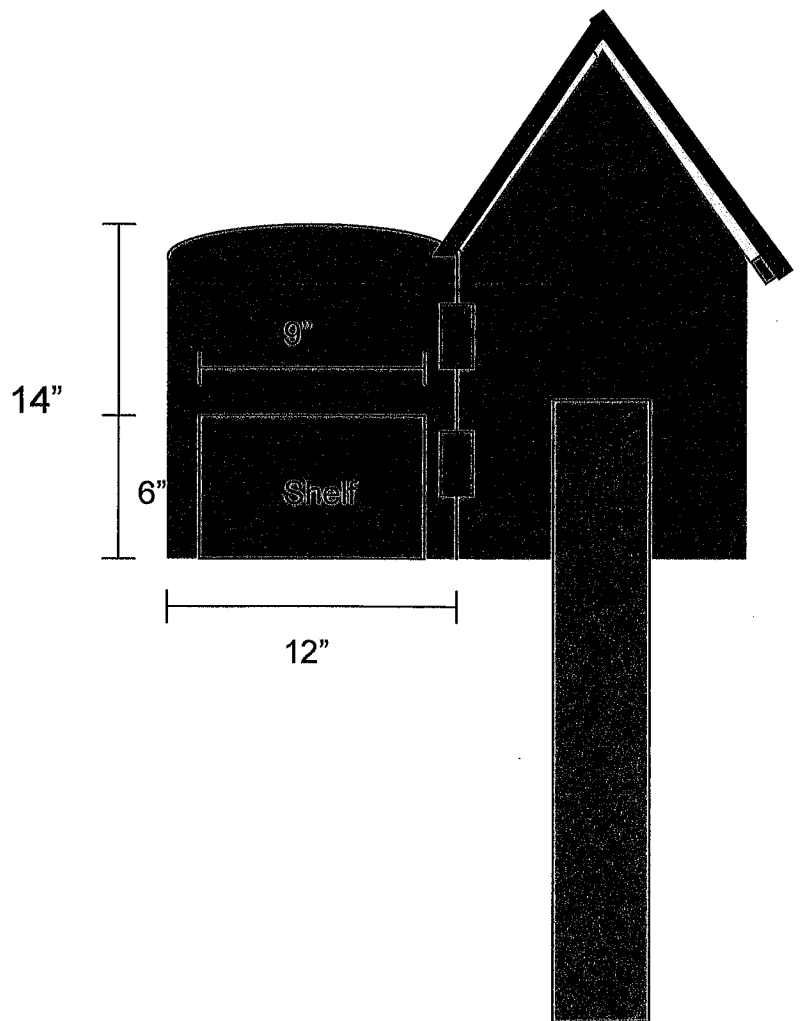
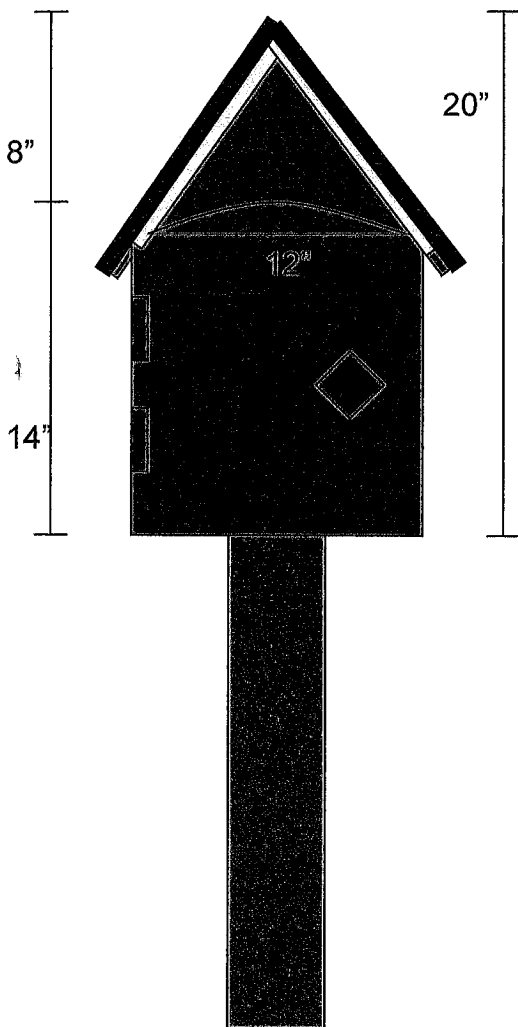

Equipment Box cont.

Front door detail,
only showing
where the cut
needs to be made.

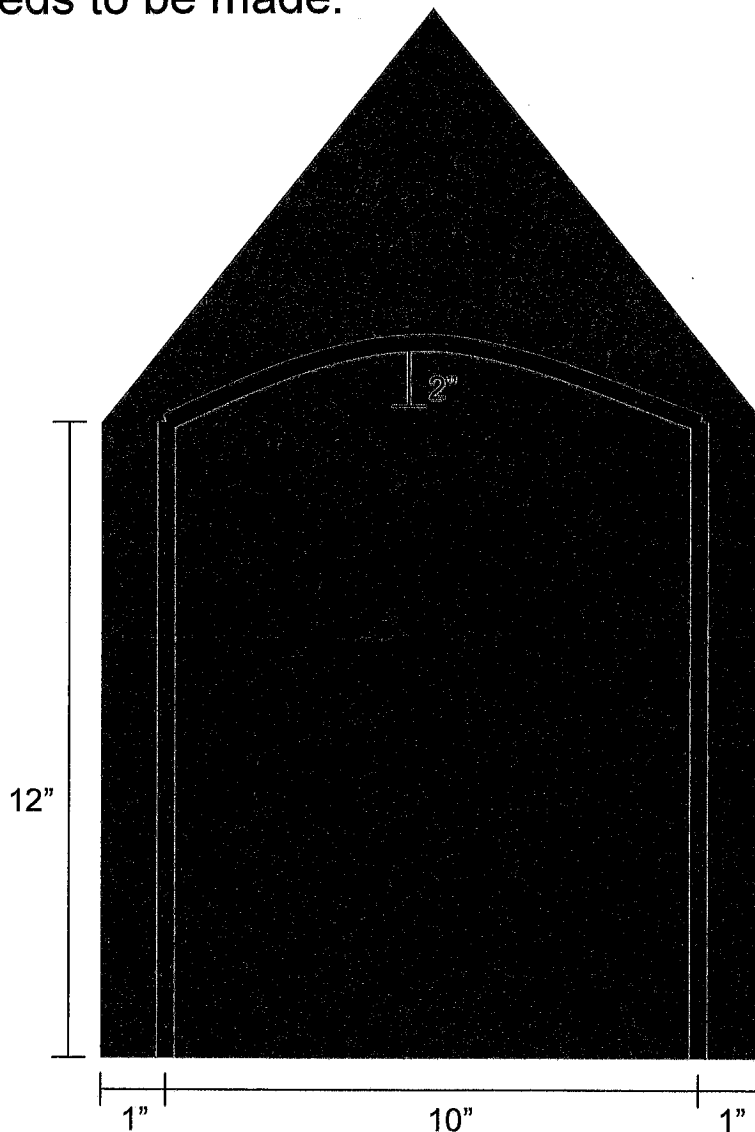

Equipment Box cont.

- 4"X4"X8' Pressure treated wooden post
- Pressure treated plywood
- Galvanized steel (hinges, handle)

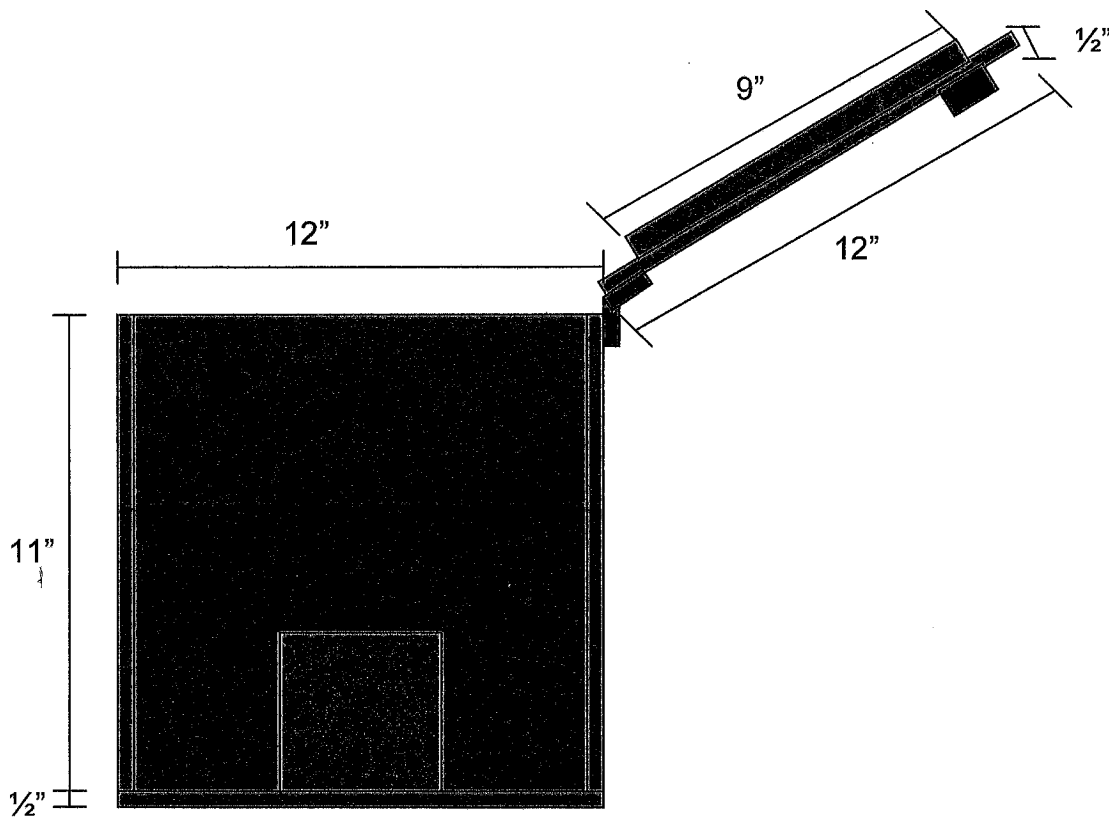

Cross
section of
inside

Equipment Box cont.

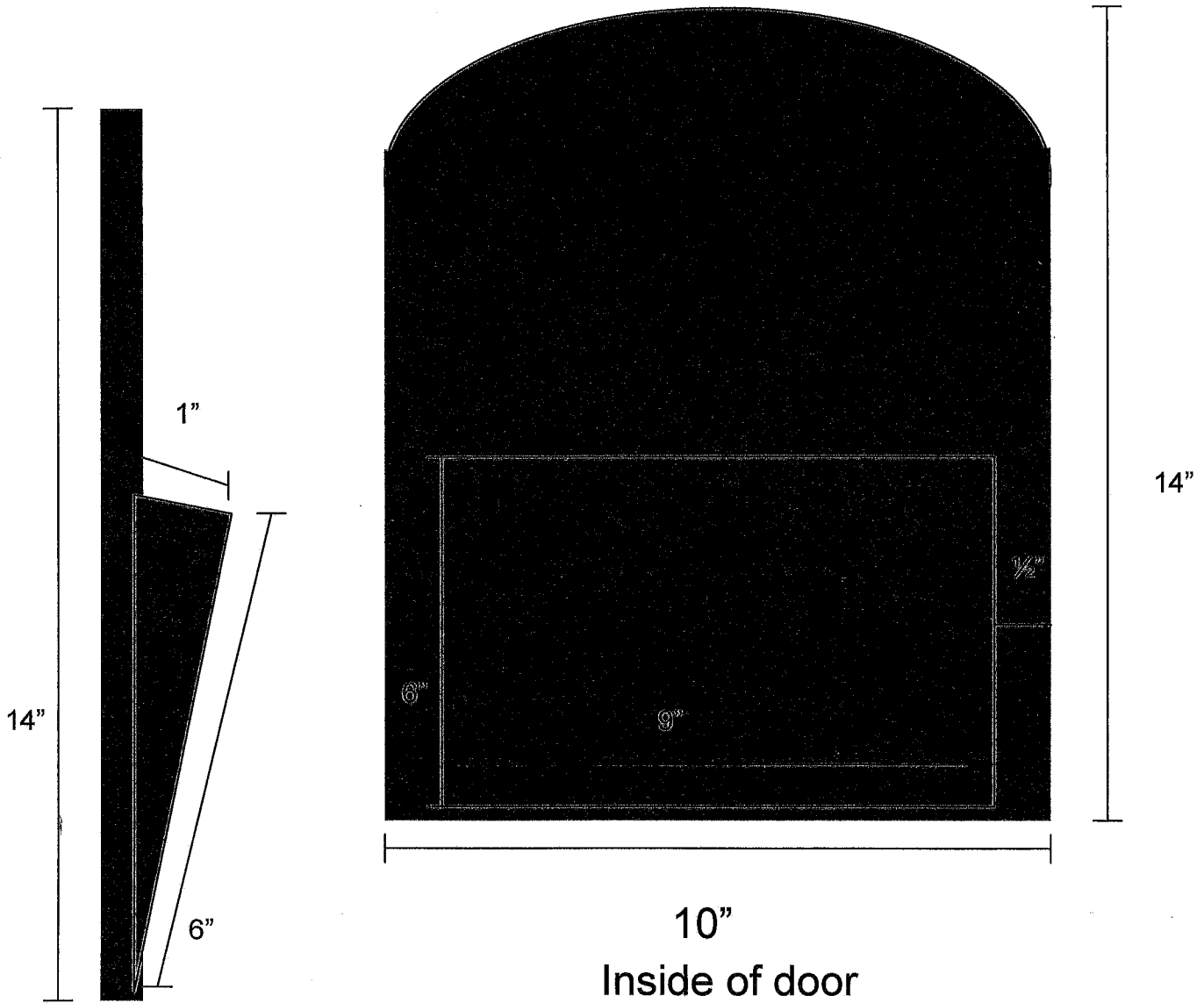

Side view of rules slot

10"
Inside of door

GOLFBALL HORSESHOES

Object of the game:

Be the first team to score exactly 21 points.

Equipment: Two goalposts and 2 different colored sets of 3 Golf Ball Bolas each.

Rules:

- 1.** A game can be played by two people or four people. If two play, the players throw the bolas at the opposite goalpost, record the score, then go to that end and throw them back at the first goalpost. If four play, then one player from each team is at each goalpost and the players throw the bolas at the goalpost opposite them. For adults, throws must be made from behind a line formed by the goalpost. For younger players the throwing line may be shortened by pacing and marking a throwing line appropriate to the age of the players. The bolas must be thrown underhand by holding onto ONE ball. **Variant:** Players may establish a throw line and play to a single goal (Allows more people to play.)
- 2.** Each of the three bars on the goalpost has a different worth: bottom bar is one point, middle bar is two points, and top bar is three points. A bola only earns points if part of the rope is touching the actual bar. If it is wrapped on a vertical post, it scores no points. It is up to the players whether or not to count points when a bola bounces off the ground, but the decision must be made before play begins.
- 3.** A round consists of players taking turns throwing bolas at the goalpost opposite them. (Ex: Player 1 throws a bola, then player 2 throws a bola. Player 1 throws second bola, player 2 throws second bola) Note: This order allows players the opportunity to knock the opponent's bola(s) off the goalposts. The first player to throw in the round is the team that scored the most points in the previous round (or last round where points were scored). Use a coin toss to decide who goes first for a new game.
- 4.** Only those bolas that are on the goalposts at the end of the round earn points for the respective teams. However, if each team has a set on the same bar, the points earned on that bar are cancelled. (Ex: Player 1 has one bola on the bottom bar and one bola on the top bar. Player 2 has two bolas on the bottom bar. Player 1 scores 3 points for the bola on the top bar, while Player 2 scores one point for the second bola on the bottom bar.)
- 5.** To end the game: The first team to score exactly 21 points wins. If a person or team exceeds 21, none of that player's or team's points count on that round. (i.e.) If a person or team has 20 points and lands on the three point rung which would put them over 21, their score remains at 20 and they must try to score exactly 21 on the next round. A **variant** is to subtract all the points scored by a team in a round that exceeds 21. (i.e.) If a player has or team has 20 points and scores 3 points, they end the round with 17.

Bench

All materials for bench will be provided by the camp

- Pressure treated wood
- Nut/bolt/washer
- Cement legs

7'

Top View

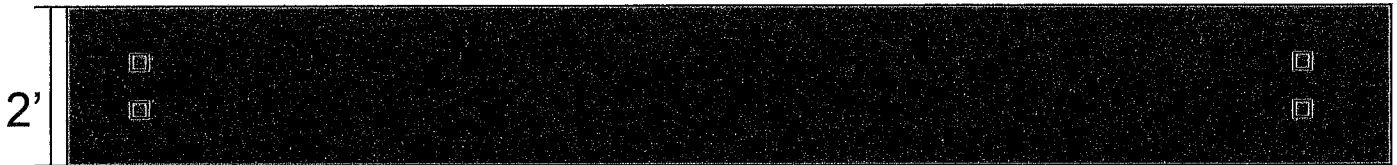

2'

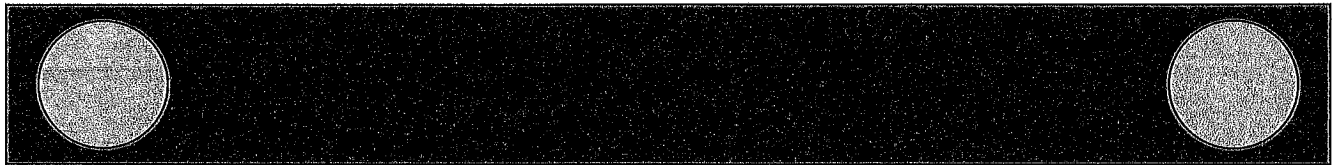

Bottom View



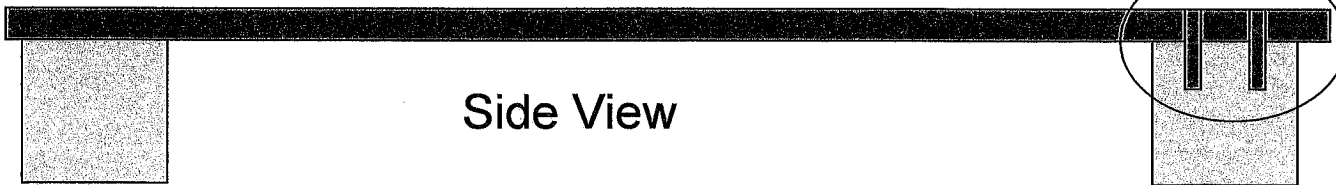

Cross Section



Side View

(See next page for detail)

Bench Counter Sinking

-  Pressure treated wood
-  Cement
-  3/8" Nut
-  3/8" Bolt
-  3/8" Washer

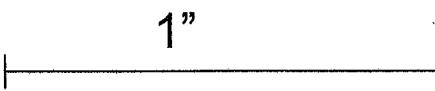
Cross Section  1"

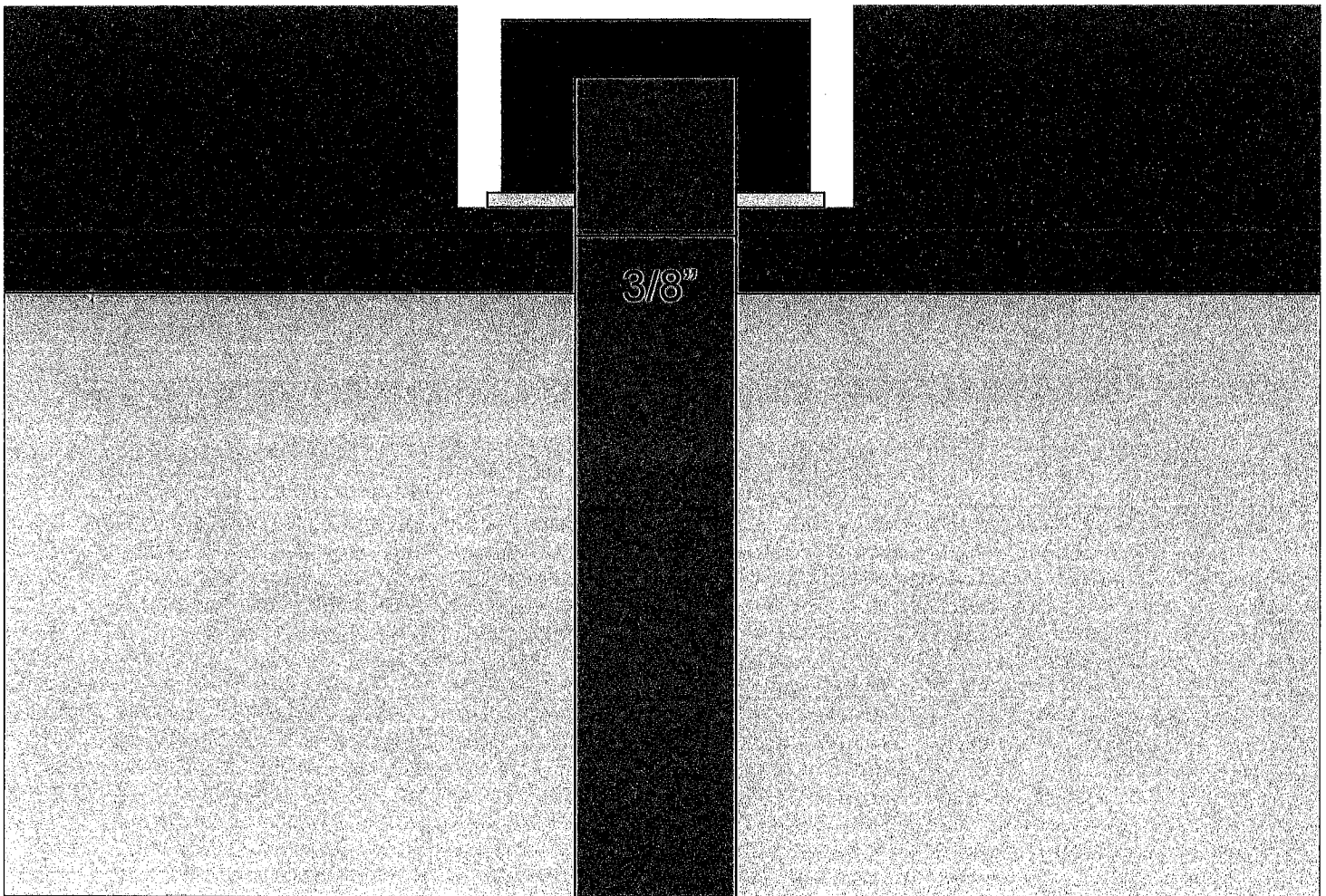

Benches

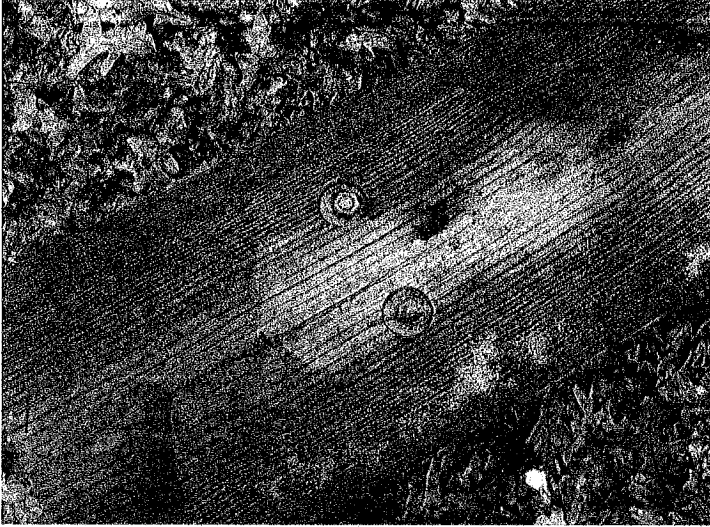

Layout of the Courts

Ground is level and drainage is not a problem

- Treated Wood (posts, bench)
- Galvanized Steel (pipes, caps)
- Asphalt Shingles

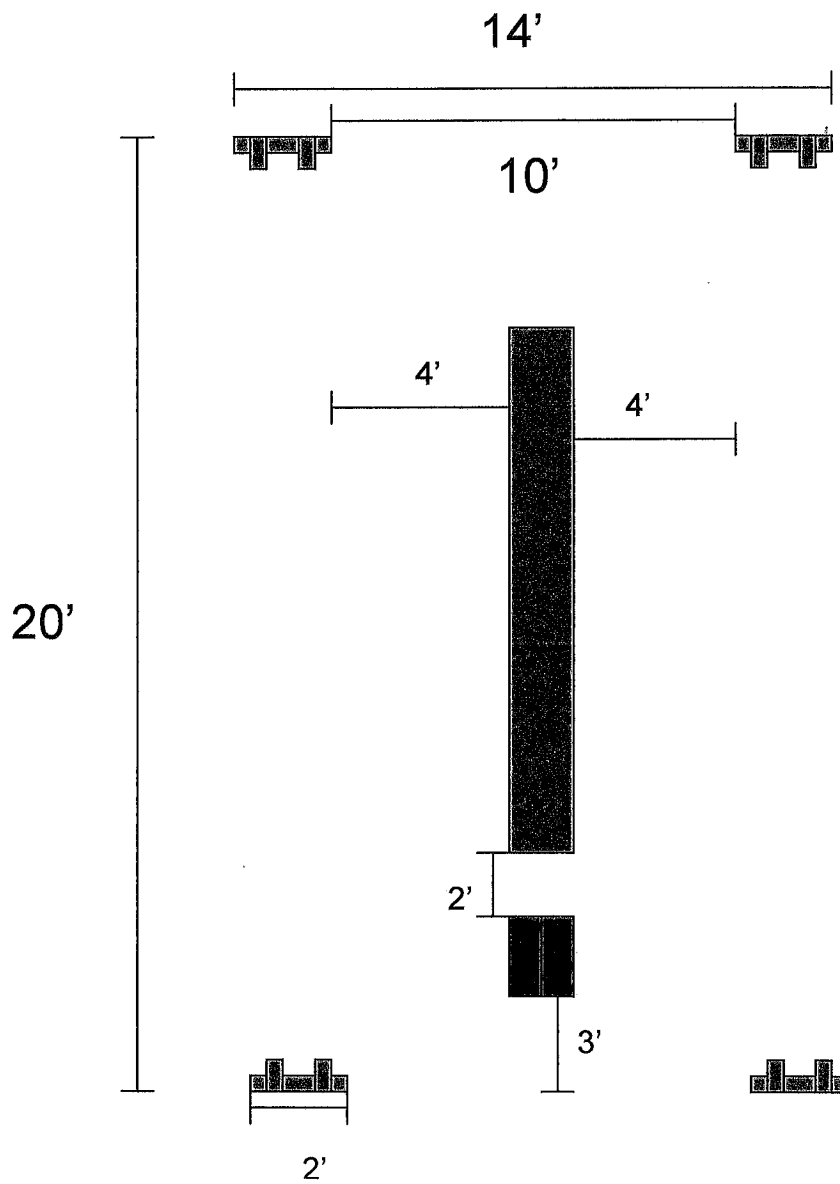

Before Pictures



Before Pictures Imposed Drawings

Please note that representations are not exact. All ladders will have three rungs, but the computer is not able to show that. This is just meant to help visualize what the finished product will look like.

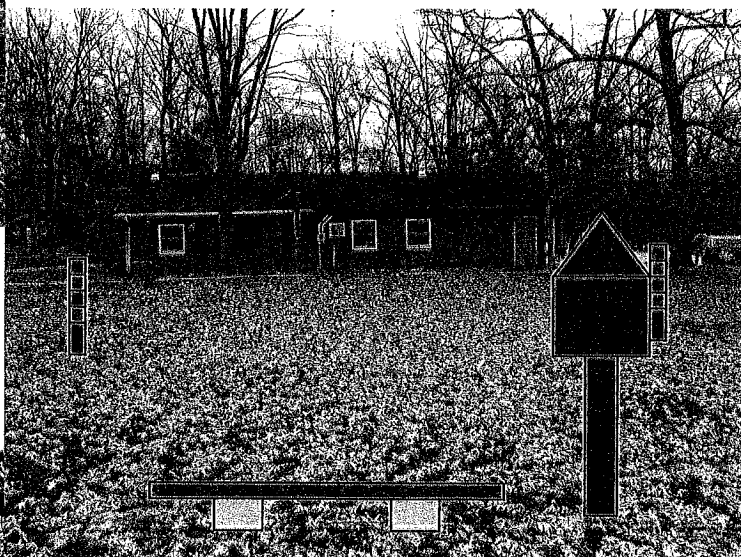

Materials List and Receipts

Item	Parts	Cost per part	Quantity	Actual Cost	
Ladders	4"X4"X8' pressure treated wooden post	\$ 6.97	9	\$ 62.73	
	3/4" galvanized steel piping	\$ 10.70	9	\$ 96.30	
	Nipple ends, 36" pipes				
	3/4" galvanized steel piping (Lowes)	\$ 9.27	3	\$ 27.81	
	50 lb fast setting concrete mix, (Quikrete)	\$ 4.37	7	\$ 30.59	
Equipment Box	3/4" galvanized steel caps	\$ 1.57	24	\$ 37.68	
	1/2"X4'X8' pressure treated plywood	\$ 23.97	1	\$ 23.97	
	Box of exterior galvanized nails 2 1/2 "	\$ 4.50	1	\$ 4.50	
	Box of construction screws 2"	\$ 2.19	1	\$ 2.19	
	Hinges, galvanized steel	\$ 2.98	1	\$ 2.98	
	Handle, galvanized steel	\$ 3.59	1	\$ 3.59	
	Felt paper, three square feet	\$ 5.00	1	\$ 5.00	
	Shingles, 2-3	\$ -	2 or 3	\$ -	
	Lag Screws	\$ 0.54	1	\$ 3.24	
	Washers	\$ 0.11	6	\$ 0.66	
	Magnetic Catch	\$ 0.89	1	\$ 0.89	
	Bolas	Golf balls (comes in pack of twelve)	\$ 6.29	4	\$ 25.16
		Twisted nylon and Polyester Rope 3/8" 50'	\$ 15.37	1	\$ 15.37
Bench	Pressure treated wood board	\$ -	1	\$ -	
	Concrete legs	\$ -	2	\$ -	
Tools needed	Hammer	\$ -	2	\$ -	
	Power drill	\$ -	1	\$ -	
	Post hole digger	\$ -	1	\$ -	
	2" Chip brush	\$ 1.15	6	\$ 6.90	
	Post level	\$ -	1	\$ -	
	Table saw	\$ -	1	\$ -	
	Scroll saw	\$ -	1	\$ -	
	Speedboring Bit 3/4"	\$ 7.47	1	\$ 7.47	
	Speedboring Bit 1/8"X6"	\$ 5.14	2	\$ 10.28	
	Misc.	Wood toned wood finish, one gallon	\$ 29.95	1	\$ 29.95
Food and Drink for helpers		\$ 50.00	1	\$ 50.00	
Blondies	Flour	\$ 13.49	1	\$ 13.49	
	Butter	\$ 5.99	6	\$ 35.94	
	Brown Sugar	\$ 39.15	1	\$ 39.15	
	Vanilla	\$ 5.95	2	\$ 11.90	
Tax			\$ 31.48		
			\$ 579.22		
	Actual Cost of Project	\$ 579.22			
	Estimated Total Cost of Project	\$ 469.87			
	Over run	\$ 109.35			
	Actual Amount Fundraised	\$ 500.00			

The \$79.22 over budget was paid for out of my own wallet.

Completion of Eagle Scout Project

This project in many ways made me a leader rather than a follower. When baking my blondies for my fundraising, I wanted to do most of the cooking myself. I realized, however, that it was too much for just me. My father and sister graciously helped out by mixing ingredients and pouring the batter. At times I felt that they were doing more of the work than me. I would tell them what to do, and they would immediately set to work, no questions asked. When building my project, I had Tristan K, Dan R, my dad, and my sister Abby help me. I would tell them where to dig, or what to stain next. They did the brute work. Without them, I would not have been able to finish this project. I also had a couple of my co-workers help me with staining the ladders, bench, and box.

Camp Lutherlyn benefited greatly from the Ladder Golf Courts. For those who do not know, Ladder golf is a game in which two teams throw bolas, which are two golf balls strung together with rope, at ladders to gain points. It is most often played with PVC pipe ladders, but mine are built out of wood, steel, and cement. Counselors over the course of the summer would take their kids there to play right before a meal. One counselor even held Bible Study on the bench that was built between the two courts every week with his campers. During Family Camp, which is a camp where whole families camp together, there was a tournament set up for Ladder Golf. Many people signed up to play in the tournament. At one point, the tournament had to stop because people who were not signed up to play were playing. That is how much demand there was to play the game. Liese Engel is part of the full time staff at Camp Lutherlyn, so she is at camp year-round. She sent an e-mail to me recently saying how much the courts are being used, even after the summer camp programs. Her letter can be seen in Tab O.

Right from the start my project had to change. I had planned to use a local pizza shop to help with my fundraiser, because many other scouts from my troop had used it successfully. When I asked them about it, literally the day after my project was approved, they said they were not doing fundraising any more. My mother came up with the idea of selling blondies, since I love to bake. Blondies are brownies but instead of being chocolate based, they are brown sugar and vanilla based. It worked very well, even better than I thought. My father, sister, and I over spring break made all of the blondies so that they would be ready to give out before Easter Sunday. It worked like a machine. Scouts had sent their orders in to me before we had started baking. I sold 100 9"X9" pans of blondies for \$5 a pan.

Next my father and I went out and bought all the materials for the project, everything from the rope to the lumber.

I started by boring out all of the golf balls. I did this by holding onto the golf ball and lowering the drill press down onto it. It may seem unsafe, but the golf ball was in an indent so that it would not fly anywhere and I was wearing safety glasses. My father and I then spent one night (while watching a hockey game) cutting all of the rope to length and fitting them inside of the golf balls. The final thing my father and I had to do was the basic building of the ladders and box. He and I spent the time in the garage cutting the lumber, putting the steel rungs into place, and even cutting out the holes in the bench where the bolts would go. I had planned that everything would be built when we went up to camp and once there, all we would have to do is put them into the ground and stain them.

That is exactly what happened. Tristan Kirneck, Dan Riethmuller, my father, my sister Abby, and I went up to camp on May 23. We unloaded all the ladders and the box from my father's truck. We started by roping off the dimensions for the courts. Patrick, the grounds crew

boss at camp Lutherlyn, suggested that the courts' dimensions be enlarged from my original plan. The courts are about 10 feet longer and 10 feet wider than originally planned. It was not a problem to change, because we had the room to expand. The courts look great and work well. We used rope and basic geometry to find the dimensions desired. Once done with that, there were nine sticks in the ground, for we had placed one where we wanted to dig each hole. We only had two post hole diggers, so I divided the group into two teams. One person would dig the hole with the post hole digger and the other would clean out the hole if needed and measure how deep it was. I went back and forth from the teams, helping and switching out if need be and also to make sure it was working well. After digging the holes we had lunch (provided by me using the funds for this project).

After lunch we started to put the ladders in the ground. We made sure that they were level and parallel with the ladder closest to them. Once we had them level and straight, we placed stringers to keep the posts where we wanted them. Next we poured in the cement. I had spent a little more money to get the quick drying cement, which did not need to be mixed with water before it was placed in the ground. Once all the ladders were up, we put the post for the box in using the same methods. The box already was made so after the cement had dried we put the box on top and bolted it on.

To finish for the day we made the bench. Because we had cut out the holes already and the cement stumps were provided by the camp, we just had to put the stumps between the courts and screw the board onto the stumps. Since we did not want anyone to damage the courts in anyway, we put caution tape around the two courts to warn people not to go near. I had also planned to make the rules for the game on 20 laminated sheets of paper. I changed it to laminate

one sheet of paper and put it inside the door for the box. This is how the camp director requested it to be done.

The final workday, June 27, happened after summer camp had already started. The campers (and also many of the staff) had played with the courts already and loved them. The final process was to stain. Wes Smid, Erica Ritenour, Alycia King, Eric Popeck, my sister and I were all on staff last summer. On one of the weekends while no campers were there, we stained all of the lumber for the courts. I had enough brushes for everyone to stain at once. We put one coat on, then went into town to do some laundry. Once back, the stain had dried and we could do one more coat. This was all done before Summer Fest and Family camp, which is a big event for camp, kind of like the open house for the summer.

Timeline

Date	Hours worked	People	What Happened
1/1/2009 to 3/31/2009		20 Me	Planning Project Planning Fundraising
4/9/2009 to 4/11/2009		24 Father 24 Sister 24 Me	We baked blondies at my house for the fundraiser. We worked 8 hours a day for three days.
	Total 72		
Between 4/11/2009 to 5/23/2009	Total 3	3 Me	Bought all materials. Cutting holes in the golf balls
		2 Me 2 Father	Cutting rope and fitting golf balls into them
	Total 4		
		3 Me 3 Father	Making the box
	Total 6		
		2 Me 2 Father	Cutting the lumber Putting rungs into ladder sides
	Total 4		
5/23/2009		6 Me 6 Father 6 Sister 6 Tristan 6 Dan	Finding dimensions, Digging holes, Lunch (not included in hours of work) Putting posts in ground, cement posts in ground Making Benches We all helped with the above
	Total 30		
6/27/2009		1 Me 1 Sister 1 Erica 1 Wes 1 Alycia 1 Erica	Staining ladders (first coat) Staining ladders (second coat) We all helped with above
	Total 6		
8/1/2009 to 1/17/2010	Total 8	8 Me	Working on project book.
Entire Project	Total Me	Total Others	Total All
		69	84
			153

Baking Blondies

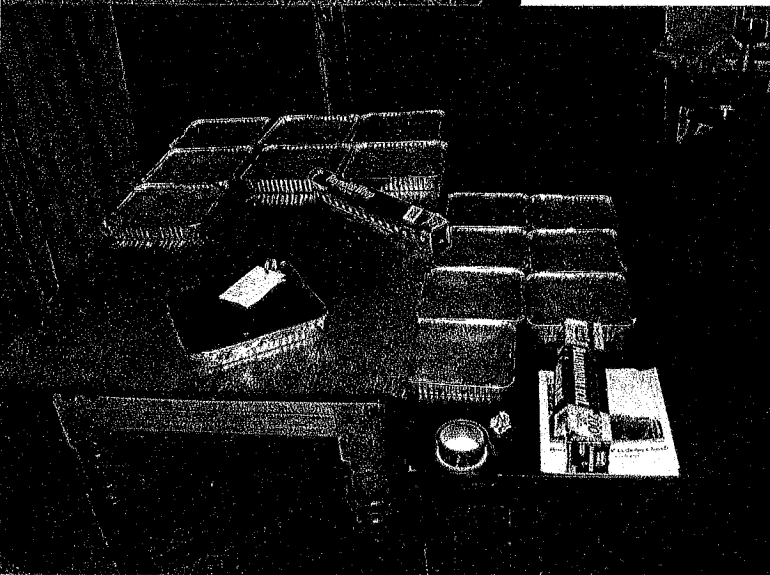
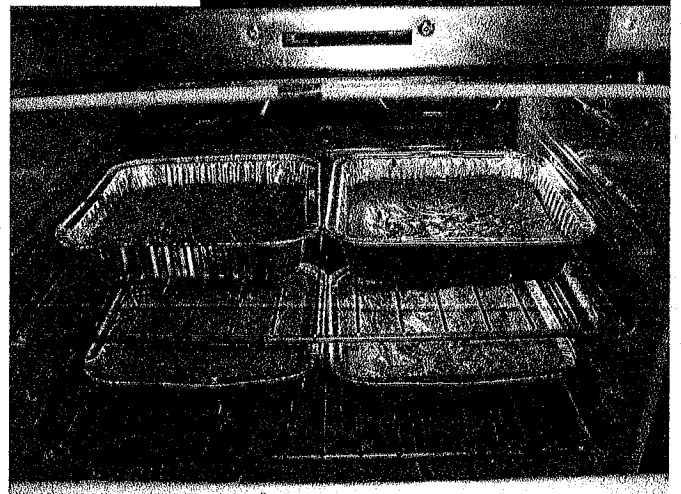
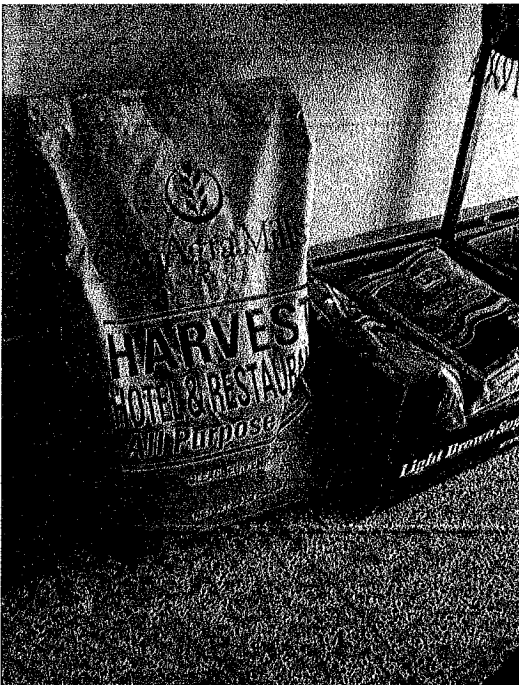
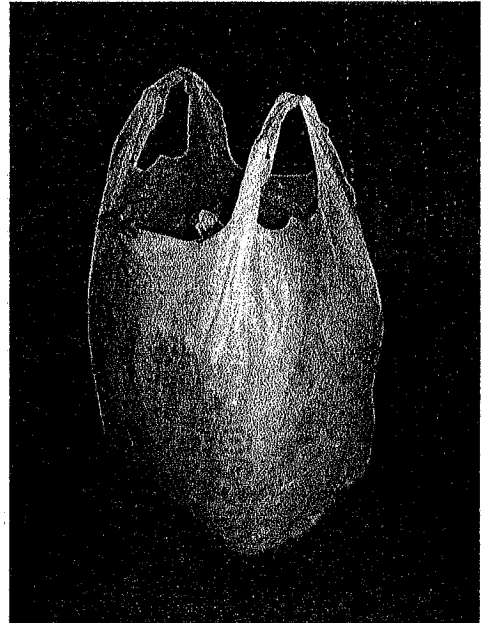

Building

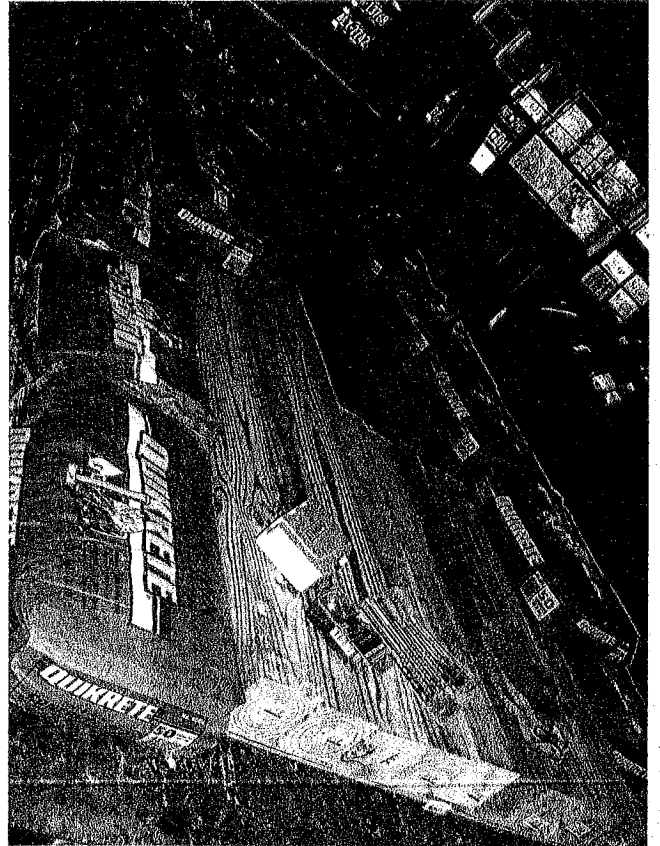
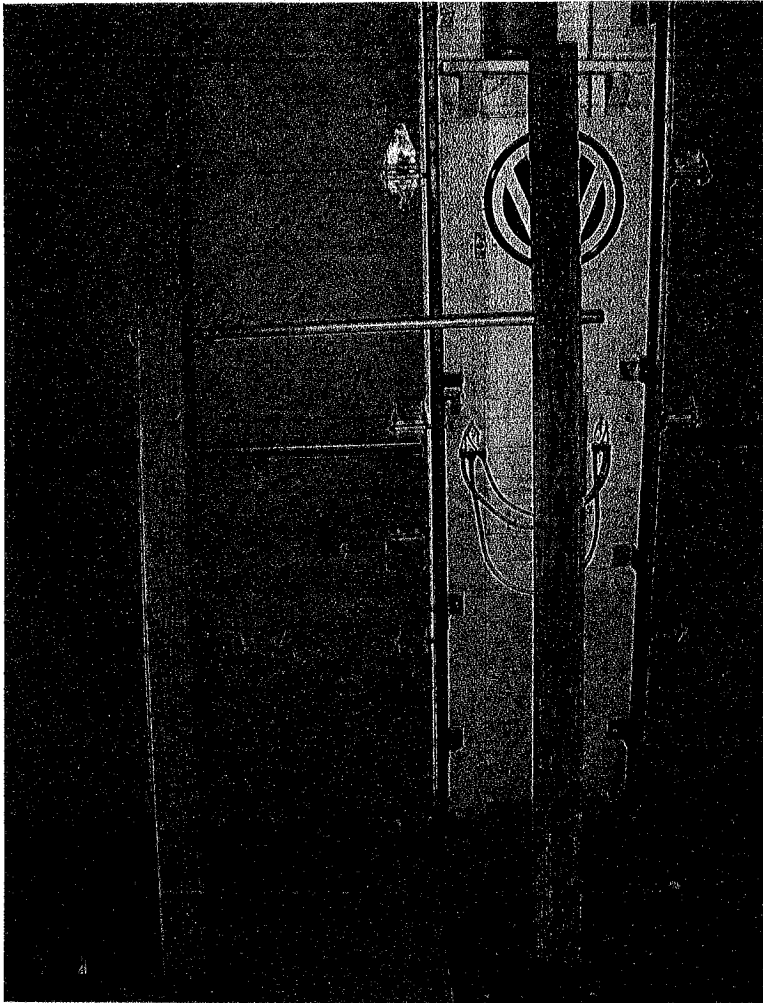

Work Day One

Part One

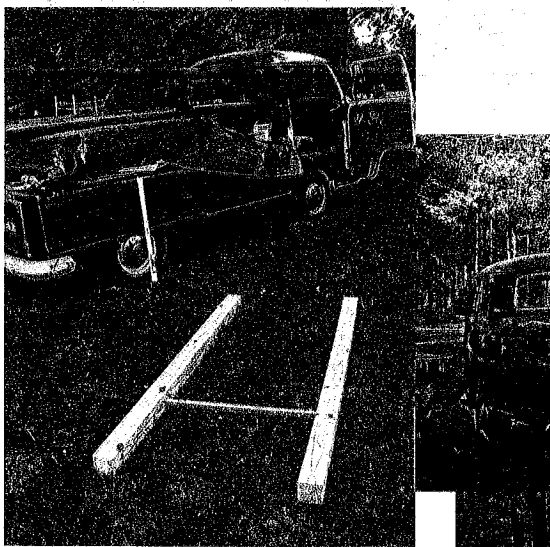
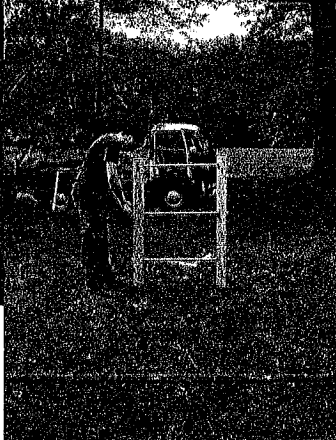
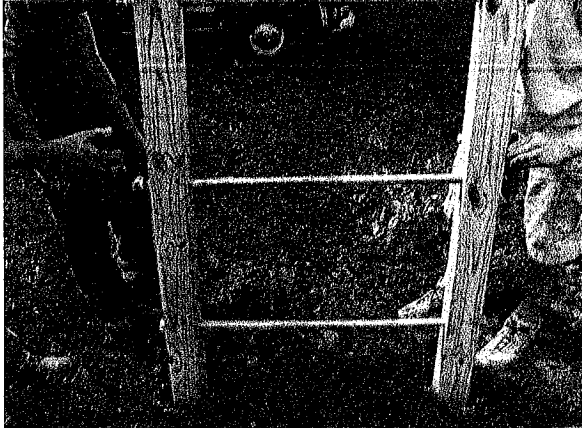

Work Day One

Part Two

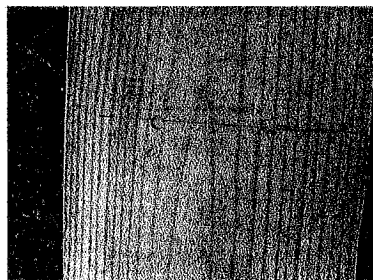
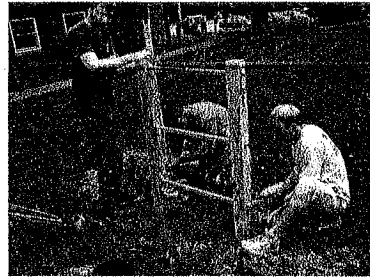
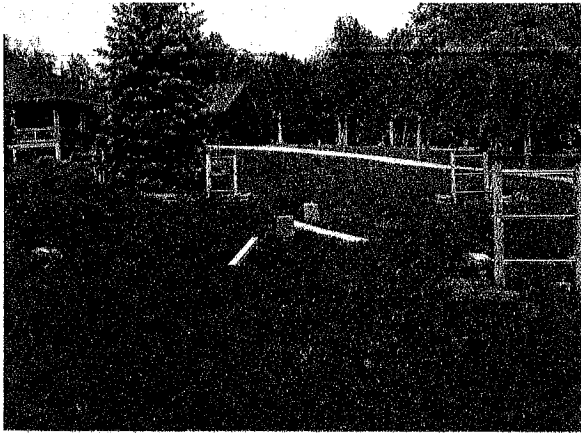
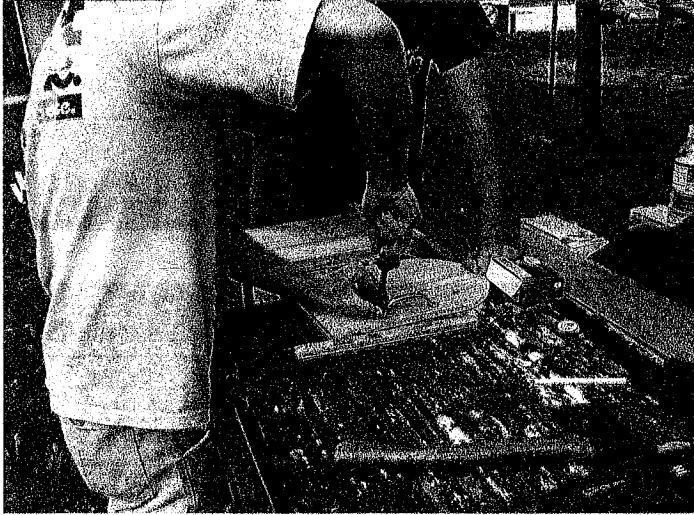
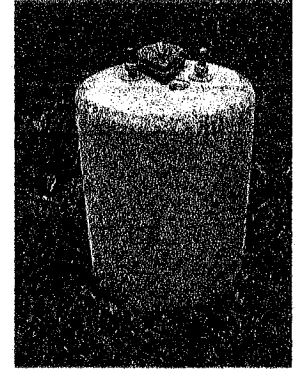

Work Day One

Part Three

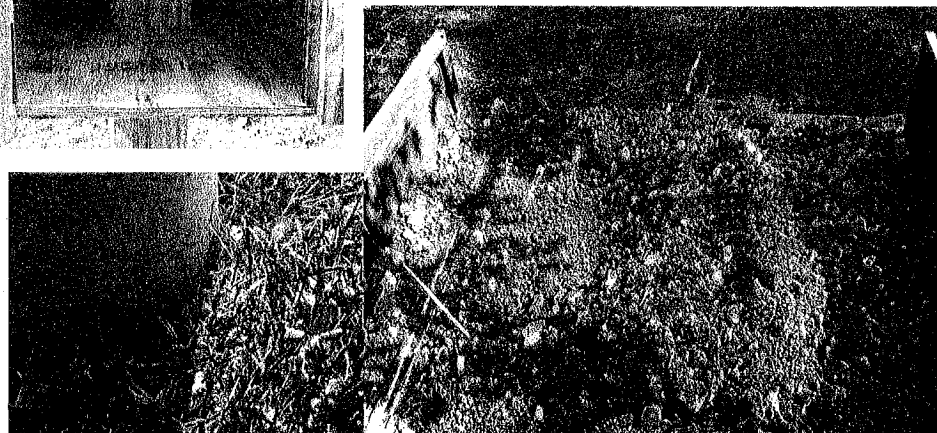
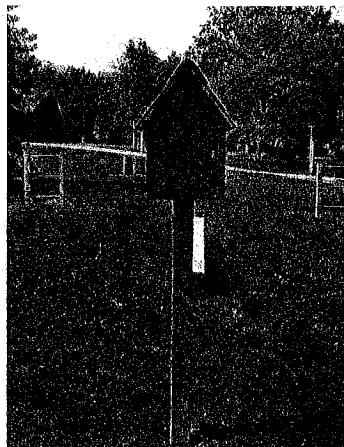
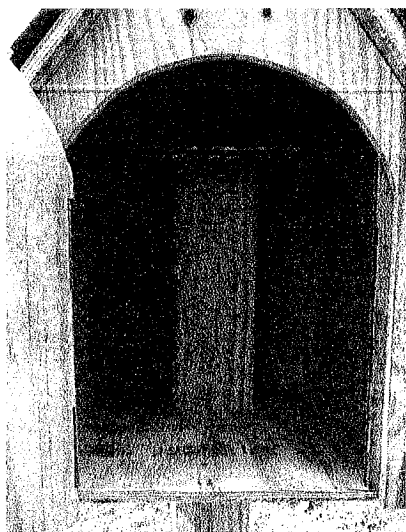
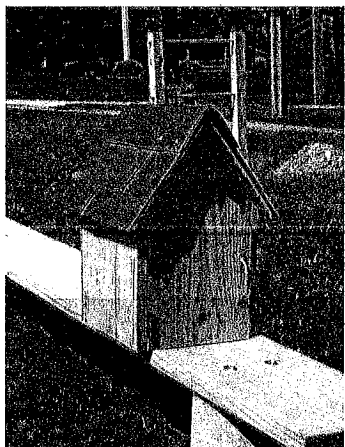

Work Day Two



Detail Shots

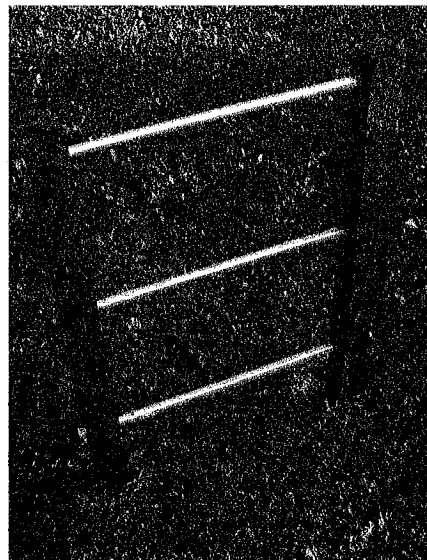
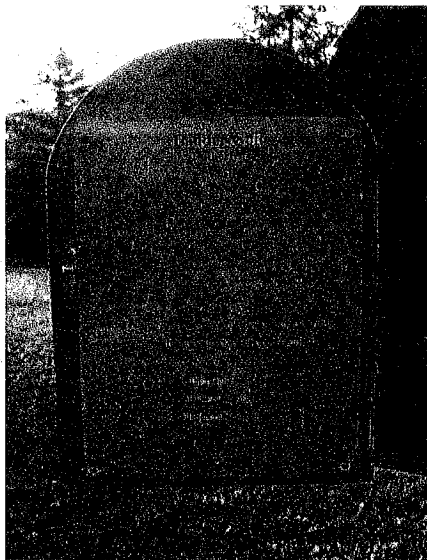
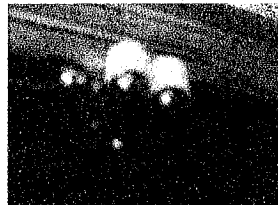
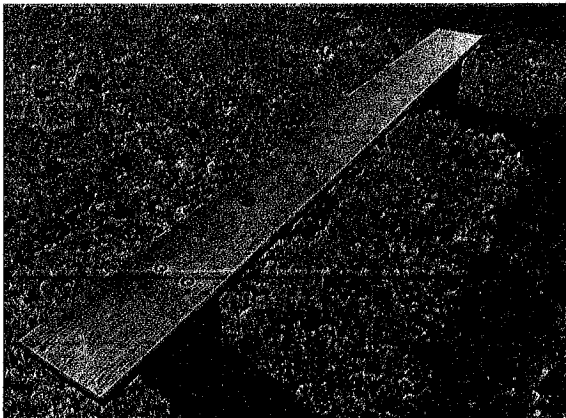
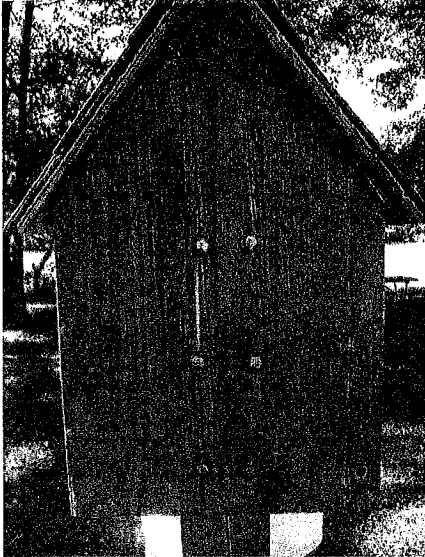

Campers Playing

Part One



Campers Playing

Part Two

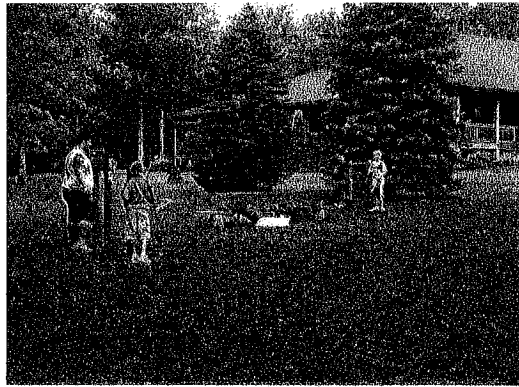

Ben's Blondies

Eagle Scout Fundraiser

Things to say to customer:

- Selling blondies for Ben Kusserow's Eagle Scout fundraiser
- Blondie: like a brownie, but brown sugar and vanilla based instead of chocolate
- Project: Ben is building two ladder golf courts up at Camp Lutherlyn
- Ingredients
 - Brown sugar
 - All purpose flour
 - Butter
 - Baking powder
 - Eggs
 - Baking soda
 - Vanilla
- \$5 for a 9X9 inch pan.
- The blondies will be delivered on April 11 to the customer's house by the scout who took the order.
- April 7: last day for orders!!!**
- Ben Kusserow's telephone numbers if there are any questions:
 - Home: 412-486-0267
 - Cell: 724-600-4631

Customer's name	Address	Phone number	Paid
- SAM FALLER		412-364-5912	✓
- Kelly Yarden		724-766-4942	✓
- PT			✓
- BAEB Njgent		412-366-0851	✓
- MARK SPALLEN		412-487-4399	✓
- Mark N			✓
- Ruth Heim			✓
- Bob Graham			✓
- STEVE KRIGNESS		412-213-0844	✓
- DAVID MARTIN CJK		412-784-9013	✓
- Jan Molnar		724-779-4713	✓
- Carol Dew			✓
- Cathy Guffert		412-486-4163	Done ✓
- Pastor Marsam			
15 - Jay Hellingner		412-992-1997	✓

Ben's Blondies

Eagle Scout Fundraiser

Things to say to customer:

- Selling blondies for Ben Kusserow's Eagle Scout fundraiser
- Blondie: like a brownie, but brown sugar and vanilla based instead of chocolate
- Project: Ben is building two ladder golf courts up at Camp Lutherlyn
- Ingredients
 - Brown sugar
 - All purpose flour
 - Butter
 - Baking powder
 - Eggs
 - Baking soda
 - Vanilla
- \$5 for a 9X9 inch pan.
- The blondies will be delivered on April 11 to the customer's house by the scout who took the order.
- April 7: last day for orders!!!**
- Ben Kusserow's telephone numbers if there are any questions:
 - Home: 412-486-0267
 - Cell: 724-600-4631

Customer's name	Address	Phone number	Paid
Elisha Liers	1154	(412) 735-4789	✓
Mrs. Son	school		✓
Mr. Stickerney	school	724 586 2018	✓
Savina Capps	School Thos. after 5:0.	(412) 862-7729	✓
Mr. Kemmer	School		✓
RD HUGHES	L. 234 G-HALL HAMPTON HS, ALLEGAN...		✓
MAGAN MURRAY	You know who	you have it	✓
Craig Syman	Band?	412-335-7885	✓
Ben Kusserow	school		✓
APP	school		✓
Mrs. Annorell	3937 Benita Dr	412-486 8678	✓
Bryte			✓
French X2			✓
Ceccati	School	412-486-6000 x1008	2✓
MC. DEMATTEO	School	412-486 6000 x1018	✓
Joe Strife			✓
Lobo 711			✓
Keith Pelkey X2	4195 Mt Royal Blvd	(412) 731-1350	✓

Zack ✓

Ladder Golf

Team Name

Members

Cabins

Give Me Your Face

Jon Steiner & Andrew H.

J2A & Miller Ctr.

Shell Shocked

Bryan & Luke Shellenbarger 41
Stable

Steiner

David & Rachel Steiner White Pine B

Dimple

Tom & Elizabeth

Staff

Teva Time

Hole in
one

Joe Shellenbarger

Kanis Nealon

Staff

Plastic

SOB CARRIAGES

41

Wilson's

Melanie + Bo Wilson

Yellow Pine B

Greetings Ben! I have to say I am very much missing you and our conversations...but on another note, I am happy to report that the Ladder Golf setup outside my office window has been getting constant attention...in fact, there is a women's retreat here this weekend and they are currently learning how to play...it is so cool! I will tell you that I have seen different groups (school groups with extra time before meals, Fathers and Sons pairs playing against other pairs, even the women are a new group to play.

I am so glad that you made this your Eagle Scout project...it is so beneficial for camp and obviously will be a great legacy at camp...and it gets people outside and interacting even when they are not at camp to do that!

I do hope you are doing well, and that your Senior year is going well!

Liese